

INFINITY ZONING QUICK START GUIDE

INTRODUCTION

Infinity Zoning incorporates cutting edge technology that sets it apart from any other zoning system on the market today. It contains all the features of Comfort Zone II plus many improvements which make it the easiest system on the market to install and use with confidence:

- It does not require a bypass damper or leaving air temperature sensor, yet the HVAC equipment is always protected from limit trips and coil freezing.
- It does not require a separate field installed power transformer.
- System can handle up to five dampers per zone.
- Infinity zoning automatically adapts itself to any equipment and duct arrangement with no adjustment from the installer.
- Patented Automatic Duct Assessment ensures that Infinity Zoning delivers superior and quiet comfort with any duct system.
- All temperature sensors and dampers remain the same as Comfort Zone II. All other components are new and are not interchangeable with CZII.

INFINITY SYSTEM COMPONENTS

The Infinity System uses a serial communication bus to pass information between major system components. 24 VAC control signals are gone (with the exception of driving dampers and conventional outdoor units). This means that Infinity Zoning will use Infinity compatible components only. A system will consist of:

- An Infinity furnace or fan coil (58MVP, 58CV furnaces, FE4 fan coil)
- An Infinity or conventional outdoor unit (38TDB, 38YDB, any single stage AC or HP with FE fan coil, any single stage AC with furnace)
- An Infinity Zoning User Interface (SYSTXCCUIZ01)
- One or two Infinity Damper Control Modules (SYSTXCC4ZC01)
- Remote Room Sensors (ZONECCORRS01) or Smart Sensors (SYSTXCCSMS01)
- Modulating dampers (DAMPREC, DAMPRND, DAMPSL)

Following is a brief description of each of these components.

Carrier Infinity Variable Speed 80 or 90% Furnace or FE Fan Coil:

The Infinity system is a fully communicating control system. Only current Carrier variable speed furnaces or FE fan coil will work with the Infinity system. Communication takes place over a four wire ABCD communication bus.

The Infinity FE fan coils will operate with any Infinity AC or HP or any conventional single stage AC or HP. The Infinity furnaces will operate with any Infinity AC or HP or any conventional single stage AC.

Infinity Zoning User Interface:

If the variable speed furnace or fan coil could be considered the heart of the system then the Zoning User Interface must be considered the brain. It is the user access into the Infinity Zone System. It allows the user to operate, program, set up, monitor, and troubleshoot the system.

From the user interface, the program schedules and desired set points, fan speeds, and a number of other selections can be set for each individual zone. It will also notify the homeowner of any maintenance reminders or problems in the system.

The Infinity Zoning User Interface (SYSTXCCUIZ01) is not the same as the standard Infinity User Interface. Only the Infinity Zoning User Interface contains the necessary programs and algorithms needed to operate the Zone System.

The standard Infinity User Interface (SYSTXCCUID01) will not work with zoned systems. However you can use the Zoning User Interface in single zone applications by going into the service screens and turning off zoning.

Infinity Damper Control Module:

The Damper Control Module could be considered the muscles of the system. It receives signals from the Zoning User Interface and then turns on the equipment and modulates the necessary dampers. All components are connected directly to the Damper Control Module. One Damper Control Module will serve up to four zones. If more than four zones exist, a second damper control module is added to the system to allow for up to eight zones.

Remote Room Sensors:

The Zoning User interface serves several different purposes. Along with its control of the system it is also the default temperature and humidity sensor for zone one. If needed this Zoning User Interface can be installed in a remote location with a Remote Room Sensor or a Smart Sensor in the Zone 1 space. However in this situation the Zoning User Interface from its remote location will still measure the humidity reading. You can't turn off the humidity sensing at the Zoning User Interface.

All other zones will need a Remote Room Sensor or a Smart Sensor to allow the User Interface to know the temperature in each of its zones. You can mix Remote Room Sensors and Smart Sensors in a system.

Remote Room Sensors are two wire sensors that are home run back to the Infinity Damper Control Module. However it is always recommended to run at least four wires for possible future installation of Smart Sensors.

Smart Sensors:

Optional Smart Sensors are available to take the place of standard Remote Room Sensors. Smart Sensors will display zone temperatures and allow the user to change

zone set points from within the room instead of returning to the main Zone User Interface. Smart Sensors have a four wire (ABCD) connection and can be wired to any other ABCD connection on the Infinity communication bus. These sensors do not have to be home-run back to the Infinity Damper Control Module. They can be daisy chained/t-tapped/wirenutted to any other device on the bus

Modulating Dampers:

Carrier's dampers are all of the modulating type and come in various sizes, using a three wire connection. They are driven both open and closed, allowing them to modulate to any desired position instead of moving only in preset steps or increments. All of Carrier's dampers are compatible with Infinity Zoning. Changes were recently made to these dampers allowing them to draw less current than older dampers assuring that up to five dampers may be connected to a single zone output – while allowing the equipment transformer to still provide all power.

PLANNING THE INSTALLATION

Selecting Zones

Usage: Group together rooms that have similar usage.

Levels: Different levels in a home need to be separate zones. Each level may be further divided into zones.

Comfort vs. energy saving: If energy saving is an objective, areas which will be unoccupied at different times need to be separated so they can selectively be set back. If maximum comfort is desired, areas with different heat loss/gain as well as different levels need to be separated. Zones in which different comfort temperatures are desired also need to be separated.

Existing ductwork: If the installation is a retrofit, the existing duct system may limit zone selection options.

Multiple dampers: Up to five dampers may be used in a zone by electrically connecting them in parallel. Multi-damper enablers are not needed.

Damper types: Round, rectangular, or rectangular slip-in dampers may be intermixed in any arrangement.

Two capacity equipment: All Infinity furnaces (58MVP, 58CVA) have two stages. ACs and HPs may be either single or two stage. If more than four zones are desired, a two stage compressor (38TDB or 38YDB) is recommended to be able to quietly supply reduced capacity to calls from smaller zones.

Duct sizing

Duct sizing practices for the Infinity Zone system are the same as previous zoning systems. . Although larger is always better, the Infinity system will make the best possible use of any existing duct system. If Infinity is being forced by load requirements and/or small ducts toward a point where a limit would trip or a coil would freeze, it will take actions to avoid these events. These actions can include partially opening selected dampers, reducing system airflow to its lowest reliable level, and ultimately staging down equipment. Because of these actions there will be no limit trips

or coil freezing, even with small ducts. Also, there is no need to balance ducts as required with a non-zoned system. The Infinity system modulates dampers automatically to provide duct balancing. Dampers open only as far as needed to provide necessary conditioning.

Return Ducts: Returns in each zone are desirable but not necessary if reasonable space exists under doors to allow supplied air to escape. It is good practice to place returns at points where uncomfortable temperatures may collect – low levels to pull cold air from floors and high levels to pull hot air from ceilings.

Why no bypass, LAT, or HPT sensors?

Not only does Infinity not need a bypass, but also a bypass must not be used. Infinity Systems have both variable speed blowers and modulating dampers. Carrier patented algorithms are used to: Maintain a safe airflow through the equipment to prevent coil freezing, limit trips, and uncomfortable leaving air temperatures. Limit maximum airflow into each zone to prevent excessive air noise. Simultaneously satisfy the set point demands of all the zones.

At initial power up and daily thereafter (1 pm every day), the system measures the size of each zone duct and learns the maximum CFM capacity of each zone based on its size and an installer set noise limit. This feature is called Automatic Duct Assessment. The Infinity system also calculates the minimum CFM required to maintain equipment safety at all times. The Infinity zoning system knows the actual CFM being delivered to each zone at all times. Combining these, it positions all dampers to optimally meet the three requirements above. If all three above conditions cannot be simultaneously met by the system, then the system will invoke a patented dynamic algorithm sequence. This includes using the variable speed blower to reduce total system airflow to a safe minimum, cracking open the zone dampers in a controlled manner to bleed excess air first into unoccupied zones and then into set back zones while preventing overconditioning of these zones.

Infinity System does not require a Leaving Air Temperature sensor primarily because there is no bypassed air to affect leaving air temperature. Minimum airflow is always maintained through the system to guarantee system acceptable leaving air temperatures and no limit trips. Typical zoning systems with conventional blowers require LAT monitoring for the following reasons:

- The bypass dumps too much conditioned air back into the equipment return causing excessive leaving air temperature.
- System air flow cannot be maintained due to high static pressure, and low air flow can cause excessive LAT.

If an Infinity blower cannot deliver the required CFM, it signals the Zoning User Interface, which responds to reduce the static pressure.

Equipment sizing

When selecting heating and cooling equipment sizes, use the same rules as for unzoned equipment. In general, do not oversize or undersize equipment due to zoning.

Air flow and temperature control

The Infinity system measures the actual temperature in each zone to 1/16 degree and responds to these minute changes.

The system continually calculates how far each zone is away from its set point to an accuracy of 1/16 degree. Most other zoning systems only know whether a zone is above or below its set point but not how far off it is from setpoint or how long it has been away from set point. Infinity system uses a proportional integral algorithm to maintain zone temperatures. Infinity dampers continuously modulate to any position between fully open and closed rather than only being just open or closed.

With these unique capabilities, the patented algorithms have been designed to simultaneously keep all zone temperatures within ½ degree of their set points. The following is a list of exceptions that can cause the zones to **not** maintain temperature set points.

- When the equipment runs out of capacity to carry the total load.
- Zones in close proximity to each other cannot be made to hold significantly different temperatures, even with dampers fully open or closed.
- A setback temperature in a zone that is too high in cooling or too low in heating when the rest of the zones have comfort settings.
- When the installer, using the User Interface service screens, sets the zone to a low air flow limit to maintain very low noise levels. (Example: A zone set to low airflow may not be able to reach comfort setpoints)

Air flow summary

The variable speed blower and the damper control algorithms work in conjunction to automatically maintain the safe airflow levels through the equipment under all conditions. Also, the airflow into any zone is limited to a maximum value. This value is set (low, med hi, maximum) for each zone by the installer in the Zone User Interface install/service screens. The default factory setting is "HIGH." The higher this setting, the more air can be delivered into a zone. Unoccupied zones are used in a controlled manner to receive excess air when needed. In a system where there are many zones of different sizes and loads, ducts that are small or when there is evidence of zones not meeting set points, the installer's remedy is to:

- Create unoccupied zones within the system
- Increase zone airflow limits in problem zones.

DOING THE INSTALLATION

Review the Wiring Diagram

The drawing below shows the Damper Control Module and all of its connection points. Please consult Damper Control Module and Zoning User Interface installation instructions for in-depth installation, sequence of operations and troubleshooting information.

Please refer to current price pages for a complete list of part numbers and options.

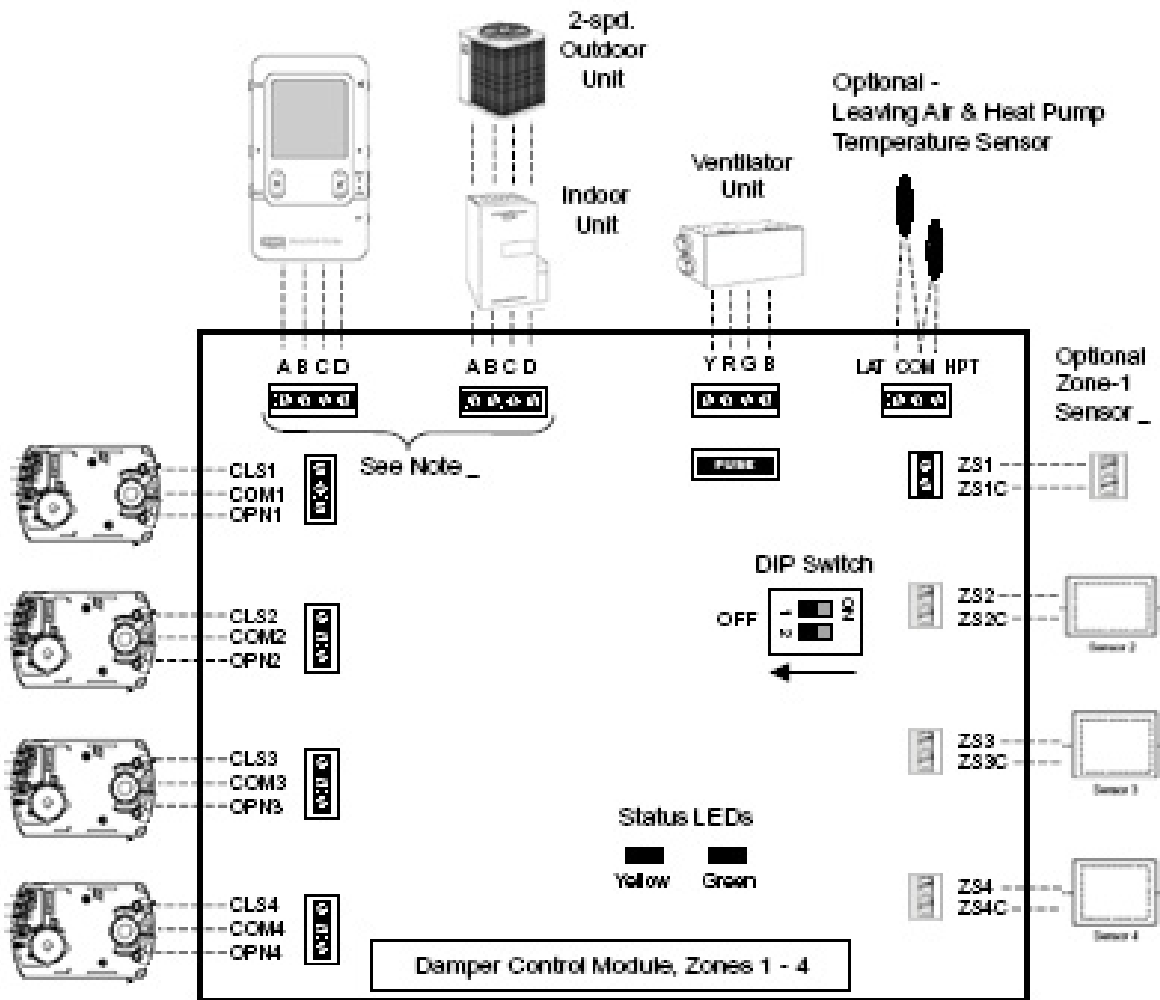

Install and wire

Follow the installation Instructions supplied with the Zone Control, Smart Sensors, Remote Room Sensors, Damper Control, and Dampers to do the physical installation. Because of its low power usage, no separate transformer is needed. Mark each Damper and Remote Room Sensor wire at the Damper Control end so they do not become mixed up. Any connection format for the ABCD bus is acceptable: home run, t-taps, daisy chain or multi drop loop. Seal behind the Zone Control and any Smart Sensors or RRS's to prevent air currents within walls from affecting temperature readings.

If you have more than 4 zones a second Infinity Damper Control Module is necessary. Wire the ABCD connection to the first Infinity Damper Control Module and turn the dip switch setting on the second Infinity Damper Control Module to the ON position.

Powering up

At power up, the system will proceed through its normal auto configuration process, finding and adapting itself to the indoor and outdoor units. All zones with Remote Room Sensors will automatically be learned. Zones with Smart Sensors will need to have zone numbers entered at each Smart Sensor. The Zone Control will inform you of this if needed. Use Smart Sensor Installation Instructions to set zone numbers. An Infinity Zoning System can have a mix of Remote Room Sensors or Smart Sensors

Startup and Automatic Duct Assessment

After all Smart Sensors are assigned, the system performs an initial startup automatic duct assessment that can take up to 6 minutes to complete

The blower is run at a constant low airflow of 175 CFM per ton (equipment is off) with all ducts closed (to measure leakage), then with each zone individually opened, and finally with all zones open. In each case the static pressure is measured using a patented algorithm based on the speed of the blower motor and other characteristics. From these static pressure measurements, the system computes the relative capacities of each zone's ducts. This assessment is automatically repeated at 1 pm each day to adjust for changes in the duct system due to blockage of registers and filter usage.

Note: The damper leakage measured is the air leakage up to and through the closed dampers. It does not measure duct leakage after the dampers. The system automatically adjusts the algorithms to account for the measured leakage.

At the end of this automatic process, Infinity Zoning System shows you the exact CFM capabilities of each zone and the air leakage (CFM) in the system. The system is then ready to operate.