



CARRIER/BRYANT SINGLE PHASE VRF

MINGLEDORFF'S TECHNICAL SERVICES



Disclaimer: The technical statements, information and recommendations contained herein are believed to be accurate as of the date hereof, but Mingledorff's does not make representations or warranties, express or implied, as to its accuracy, its completeness, or the results to be obtained. The information is being provided for informational purposes only and is intended for use by persons having adequate skill and expertise regarding the proper selection, use and application of the products and recommendations and at their own risk and discretion.



Differences between VRF and DLS

MULTIZONE DLS VS VRF

- *Refrigerant Piping Design*
- *Overall Pipe Length*
- *Low Voltage Wiring (Individual vs Daisy Chain)*
- *High Voltage Power (Where the Indoor units derive power.)*
- *Thermostats*
- *EEV locations.*
- *Application and Thermal Zone Issues*

*Individual refrigerant lines
Per circuit*



*One refrigerant circuit to
catch all indoor units*

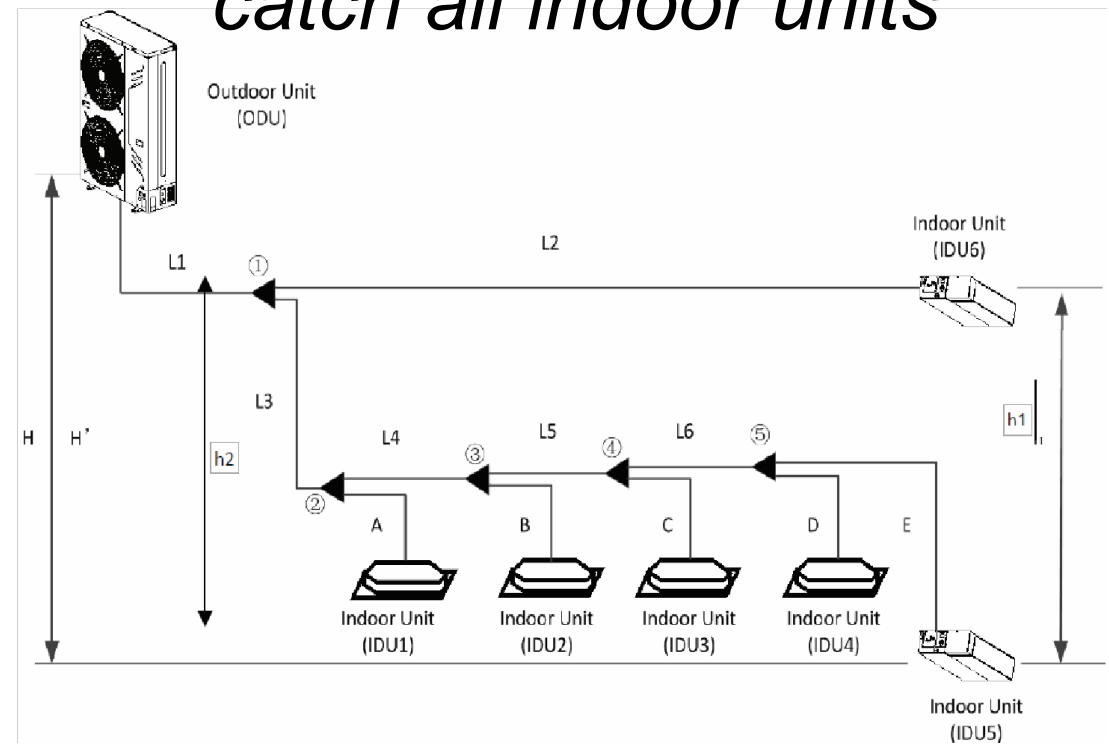

DLS VS VRF OVERALL PIPE LENGTH



KBTU	DLS	VRF
18k	131 ft.	N/A
24k	197 ft.	492 ft.
30K	263 ft.	N/A
36K	328 ft.	492
48K	328 ft.	492
60K	N/A	492

DLS VS VRF COMMUNICATING WIRES

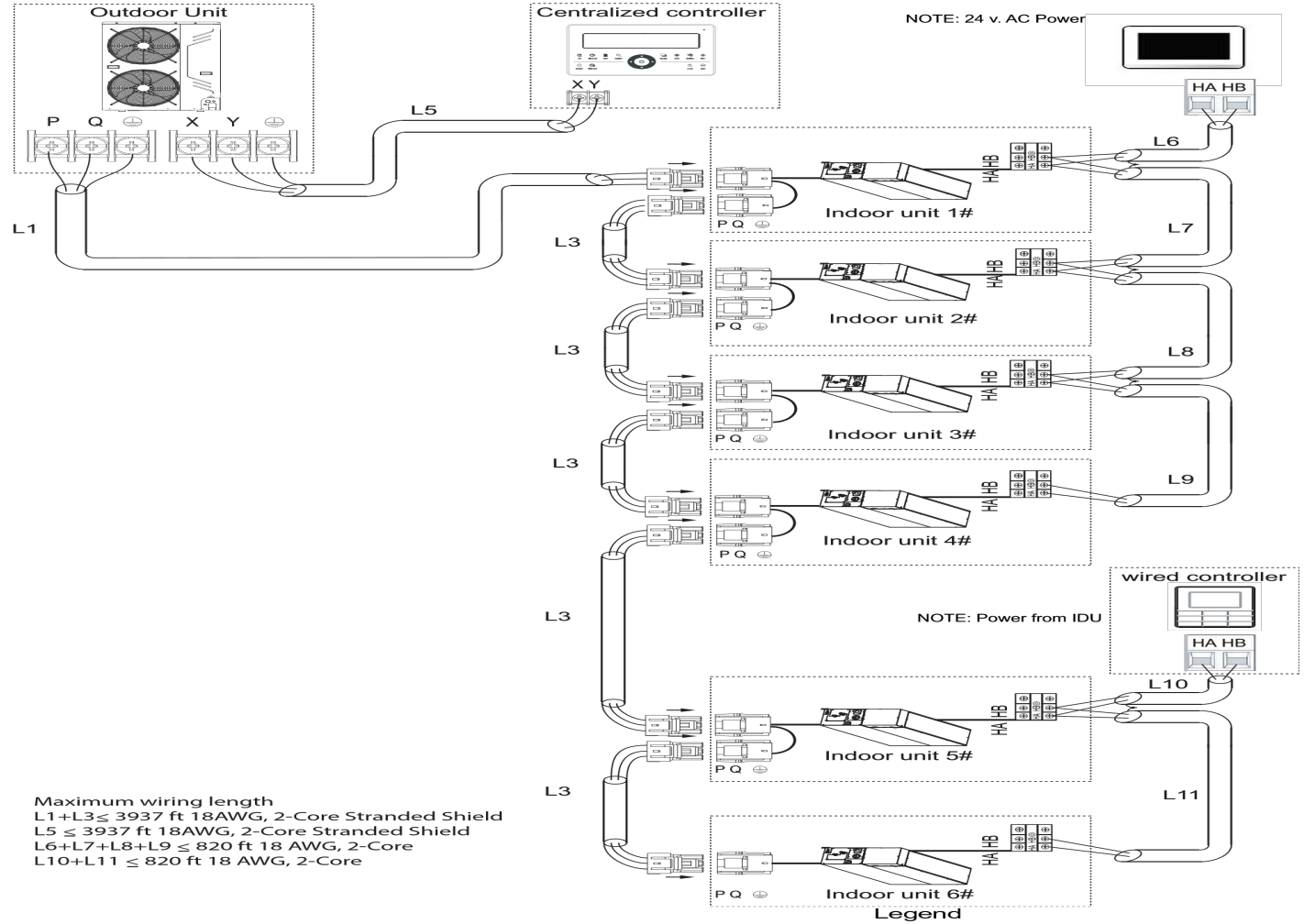

DLS VS VRF HIGH VOLTAGE WIRING



DLS

High voltage line per indoor unit comes from the Outdoor Unit.



VRF

Each Indoor unit needs its own power source, however it can all come from one breaker.

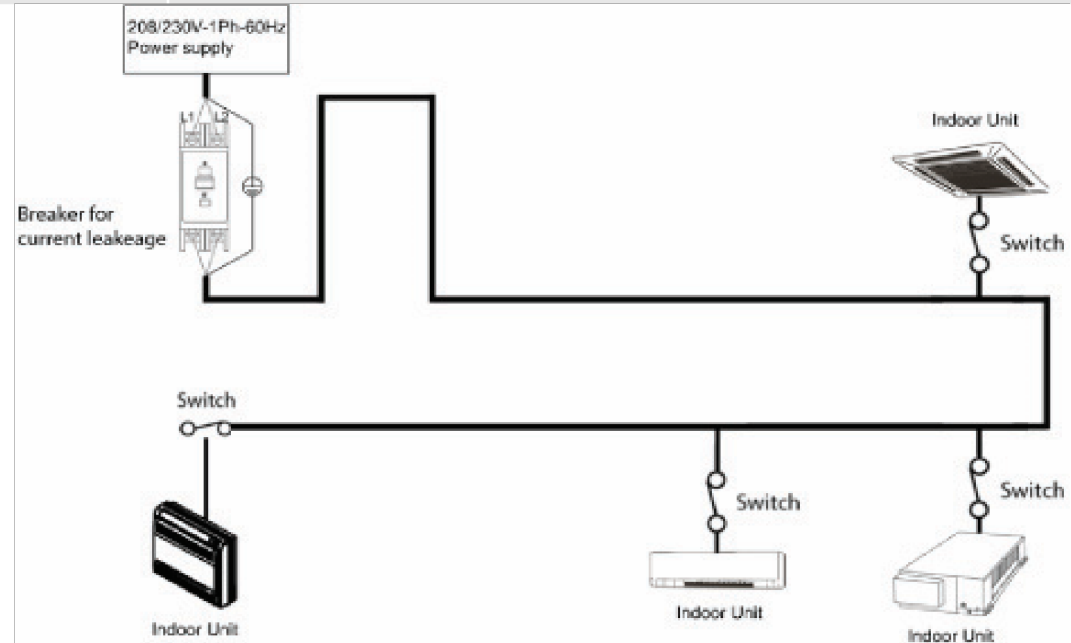

ksacno601aaa



*Specific thermostats
Per indoor unit 5v or 12v*

40vm90003



*One thermostat can
Control all styles of IDU's*

DLS VS VRF EEV LOCATION



DLS	VRF
Outdoor unit Only	Indoor and Outdoor units.

DLS VS VRF APPLICATION IMPROVEMENTS



DLS	VRF
IDU's should be installed in same thermal zones to avoid over conditioning in some zones	IDU's can be installed in any area of the building due to indoor EEV's



Carrier/Bryant Single Phase VRF

■ COURSE OBJECTIVES

- Utilize VRF technology and application
- Explore the Carrier VRF product line features and specifications
- Examine Carrier VRF product functions and controls
- Review installation procedures, best practices, and testing
- Identify and review start-up procedures
- Discuss troubleshooting codes and best practices





Section 1
WHAT IS VRF?



Section 2
PRODUCT



Section 3
FUNCTION AND CONTROL



Section 4
INSTALLATION



Section 5
Pre-Start Procedures



Section 6
TROUBLESHOOTING

WHAT IS VRF?

WHAT IS VRF

- Ability to control multiple rooms at different temperatures
- Refrigerant flows to the unit that is calling for heating or cooling
- System where multiple indoor units (up to 9 depending on model) can be connected to a single outdoor unit
 - Single phase HP is offered in 3,4, and 5 ton
- Fan coils are controlled individually or by group control



WHAT IS VRF



Outdoor Unit

- Controls Compressor Frequency and Fan speed
- Maintains Operational Mode



Indoor Units

- Transfers Heating and Cooling to Space
- Allows for Optimal Zoning



Controls

- Controls Space Temperature and Indoor Unit Fan
- Remote or Central

WHAT IS VRF



- Transfers heating and cooling directly to the space
- Measures Return Air Temperature
- Electronic Expansion Valve (EEV) adjusts to meet set point
- Filters and distributes the air



CONTROLLER

- Allows for individual or group control of indoor unit
- Takes user desired space set point, fan speed, mode selection

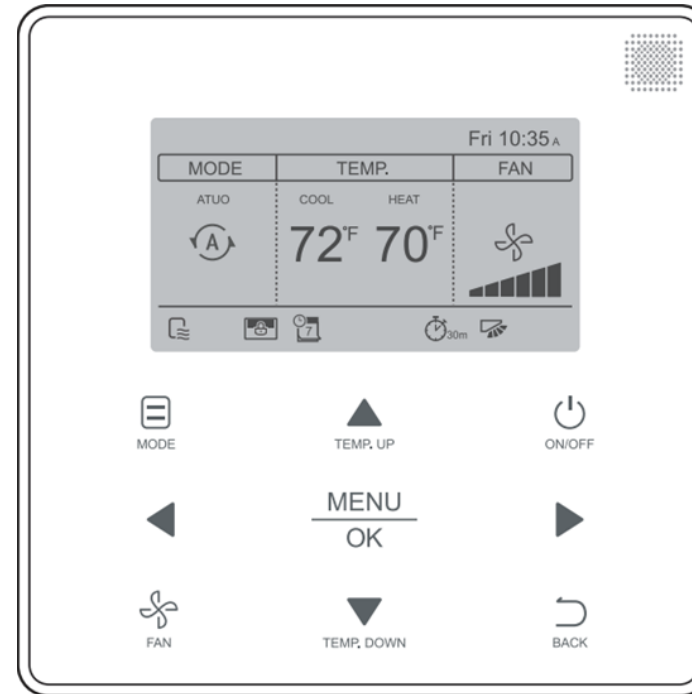

VRF TECHNOLOGY

A *fixed speed compressor* is susceptible to electrical damage



An *inverter-driven compressor* is less likely to fail at start-up because it sees a soft-start, making it **MORE RELIABLE**

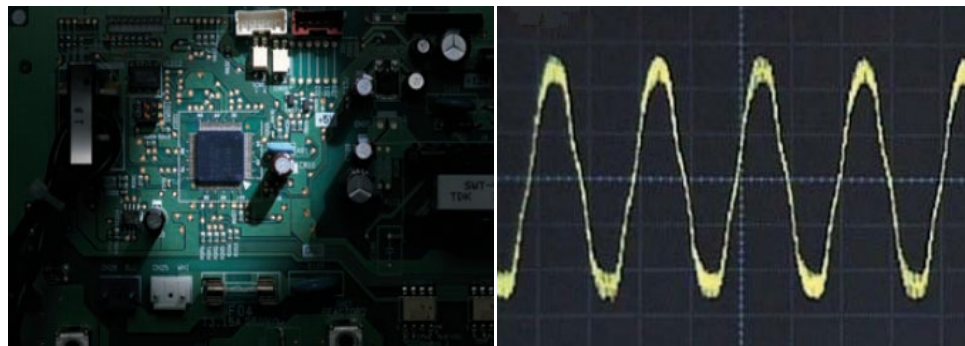

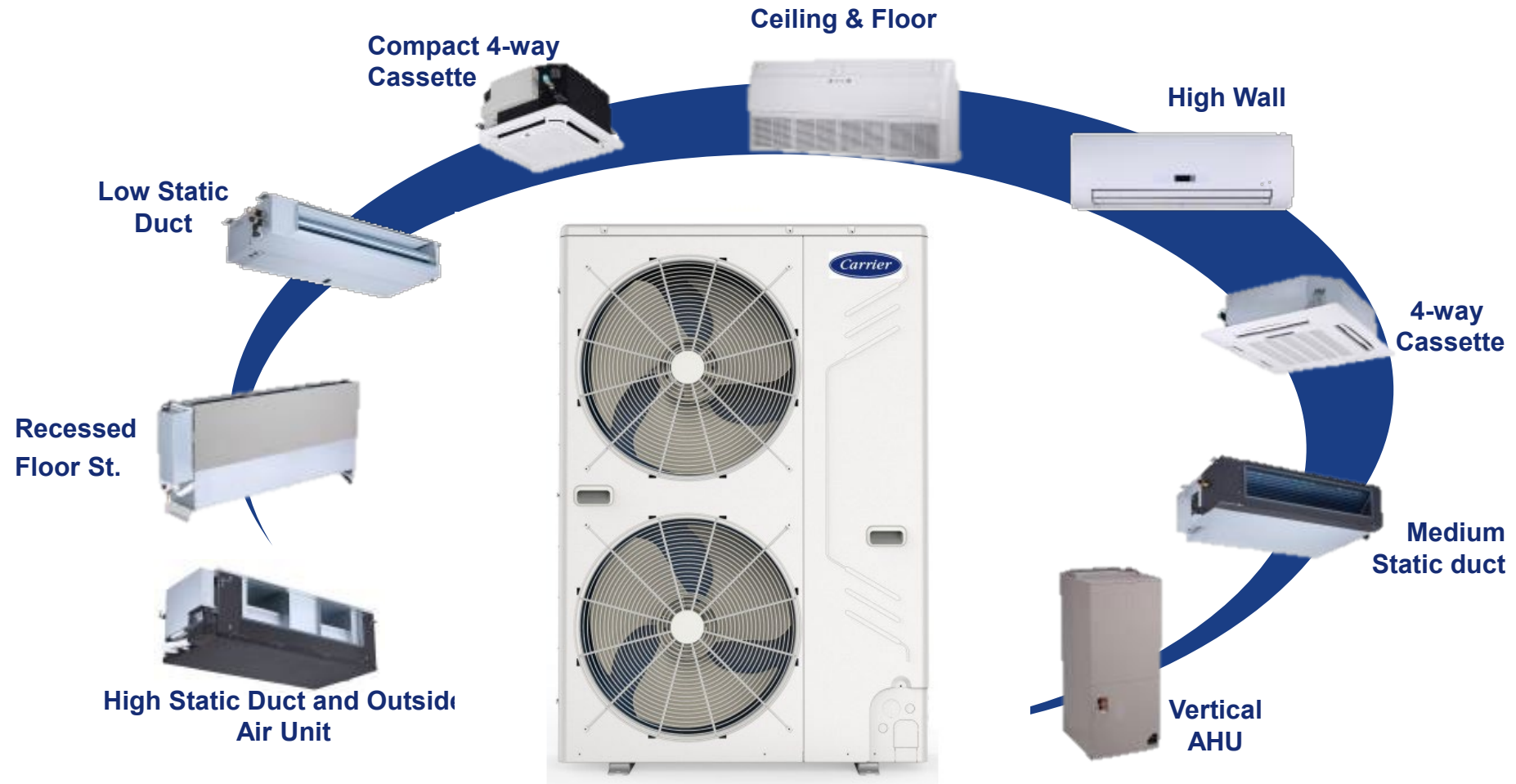

36,000 to 60,000 Btuh

3.0 to 5.0 Tons

The Carrier 38VMH single-phase VRF heat pump system is a combination of an outdoor unit with multiple style indoor units connected by refrigerant piping and wiring. The outdoor units have stacked dual condenser fan with side discharge.

Compatible Indoor Units & Controls

The 38VMH single-phase heat pump system can be matched with 10 different IDU's and 3 different controllers. 40VMA, 40VMC, 40VMF, 40VMH, 40VML, 40VMM, 40VMR, 40VMU, 40VMV, 40VMW & 40VM9 (controller)



Product Features

- Up to 18.6 SEER cooling efficiency
- Up to 10.0 HSPF heating efficiency
- Available in 3, 4 & 5-ton capacity range
- 208/230-1-60Hz power supply
- Ability to connect up to 9 multiple style indoor units on a 5 ton system
- 2-pipe heat pump system
- High performance outdoor unit with Inverter-driven scroll compressor
- Cooling Operating Range: 5° F to 118° F
- Heating Operating Range: -13° F to 64° F
- Connected capacity 50-130%
- Quiet outdoor operation, as low as 58.7 dB(A)

■ Outdoor

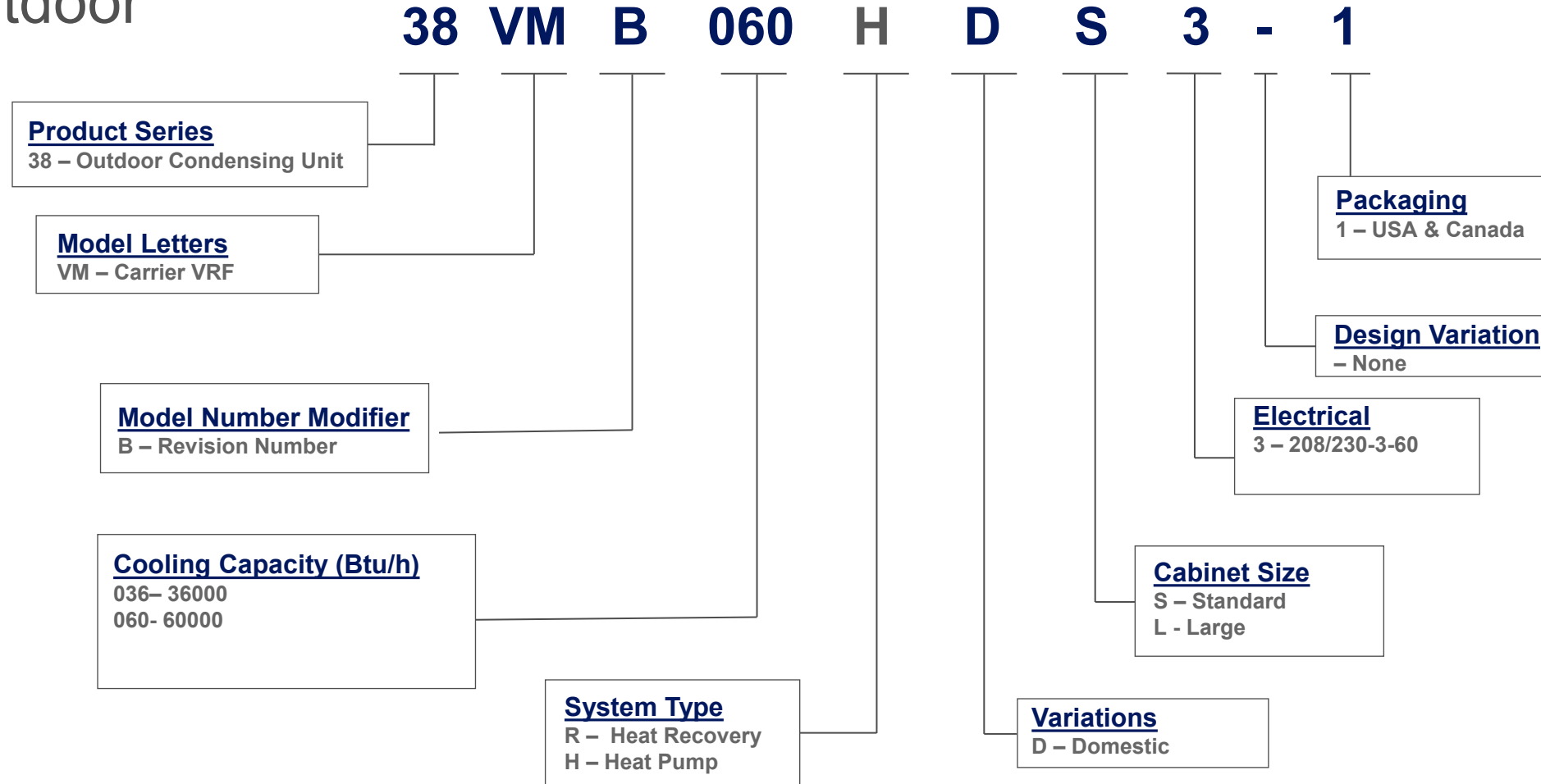



- 10 Indoor Unit types
- 7,000 – 96,000 Btu/h
- 208/230V-1Ph-60Hz
- Integral ventilation and condensate lift mechanism – most models

■ INDOOR PRODUCT

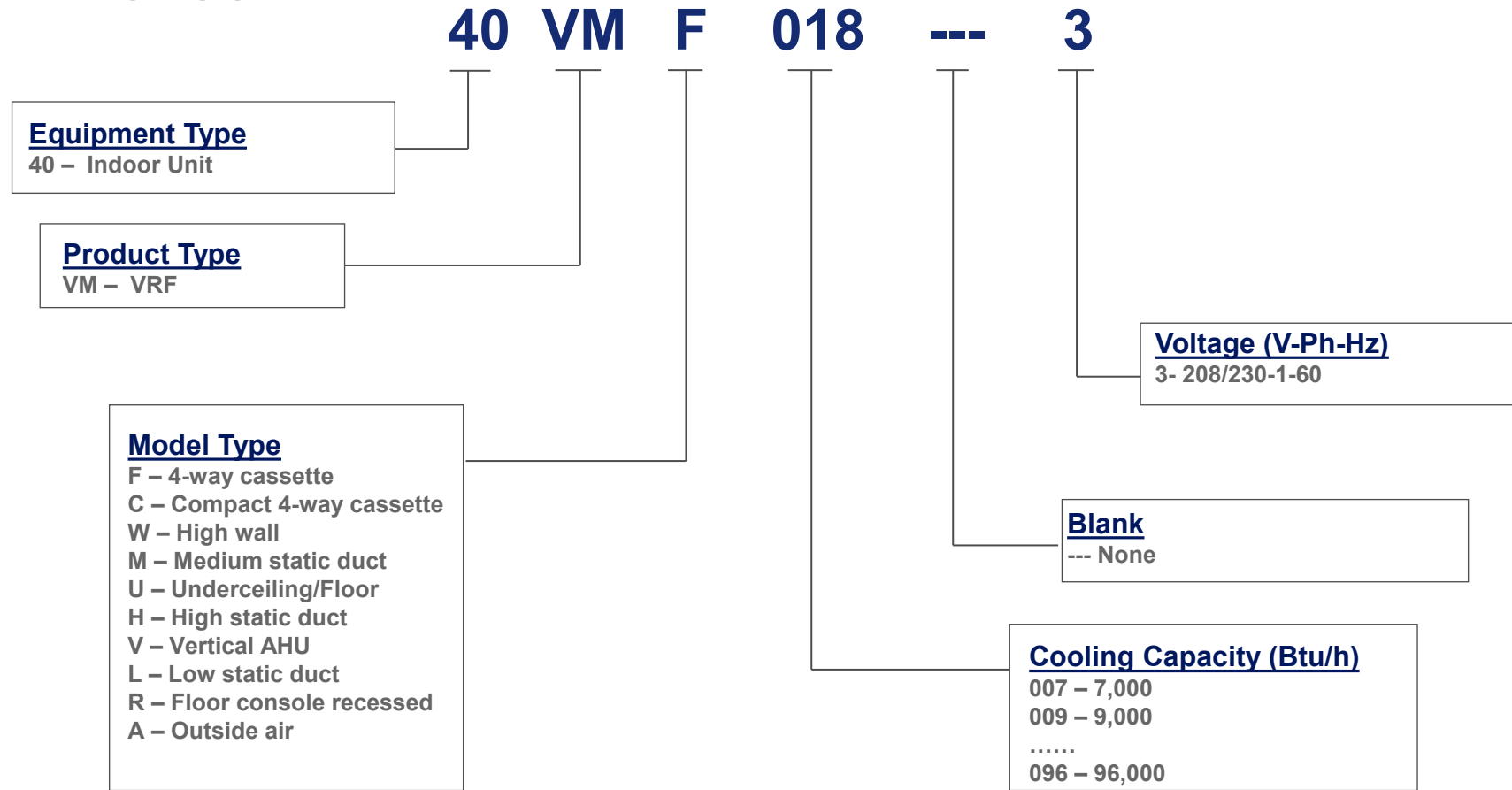

PRODUCT

REMOTE CONTROLLERS

- Wireless remote controller (40VM900001)
- Wired remote controller – Non-Programmable (40VM900002)
- Wired remote controller – Programmable (40VM900003)
- Touchscreen wired remote controller (40VM900005)



CENTRAL CONTROLLERS

- Touchscreen Centralized Controller (40VM900006)
- Energy Management Module (EMM) (40VM900051)
- BACnet/IP (40VM900052)
- LONWORKS (40VM900053)



WIRED REMOTE CONTROLLER

Non-Programmable (40VM900002)



- Simple, Easy to Use
- ON/OFF
- Group Control (Max 16 IDU)
- Mode Setting
- Fan Speed Setting
- Set-point Display
- Swing Setting
- Addressing Capability
- Back light
- Dual set-point control
- Set temperature range limiting
- Room Temperature Display
- Error Display
- Touch Button
- 1F temperature indication

WIRED REMOTE CONTROLLER

Programmable (40VM900003)



- Simple, Easy to Use
- ON/OFF
- Group Control (Max 16 IDU)
- Mode Setting
- Fan Speed Setting
- Set-point Display
- Swing Setting
- Addressing Capability
- Back light
- Dual set-point control
- Set temperature range limiting
- Room Temperature Display
- Error Display
- Clock & Weekly Scheduling
- Touch Button
- 1F temperature indication

TOUCHSCREEN WIRED REMOTE CONTROLLER

(40VM900005)

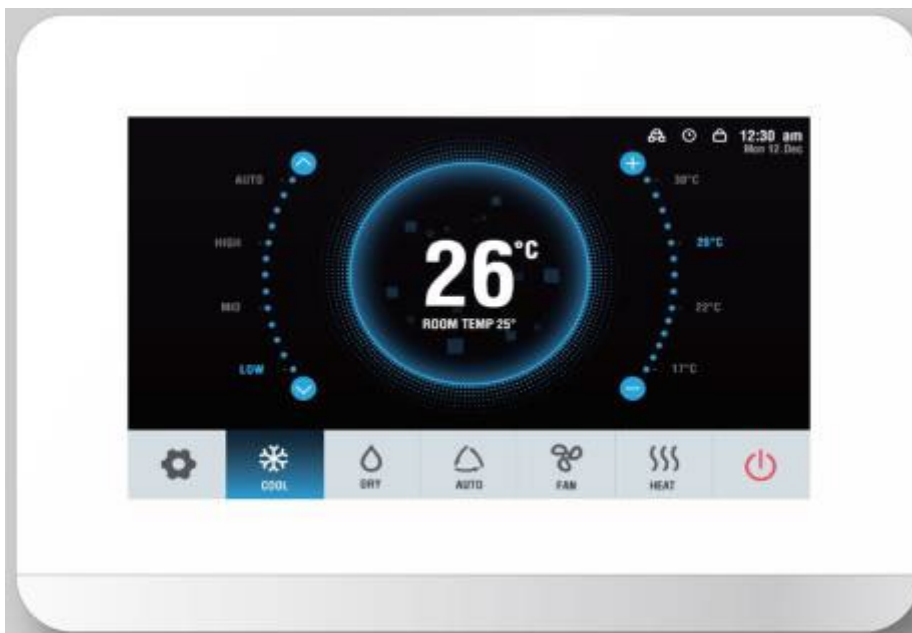

- Display is 800*480 resolution
- ON/OFF
- Group Control (Max 16 IDU)
- Mode Setting
- Fan Speed Setting
- Set-point Display
- Swing Setting
- Addressing Capability
- Back light
- Dual set-point control
- Set temperature range limiting
- Room Temperature Display
- Error Display
- Clock & Weekly Scheduling
- Touch Screen
- 1F temperature indication

TOUCHSCREEN CENTRALIZED CONTROLLER

(40VM900006)



- 10.1 inch screen, 1200*800 resolution
- 3 level of account management ,can set up 20 users
 - 2 administrators and 18 normal users are included
- Remote access
- Alarm notification via email
- Fire alarm and interacting information, 4 path DI and DO
- Recognize units automatically
- Controls up to 384 IDU
- Mode Setting, Fan Speed Setting, Set-point Display
- Swing Setting
- Dual set-point control
- Set temperature range limiting
- Error Display
- Clock & Weekly Scheduling

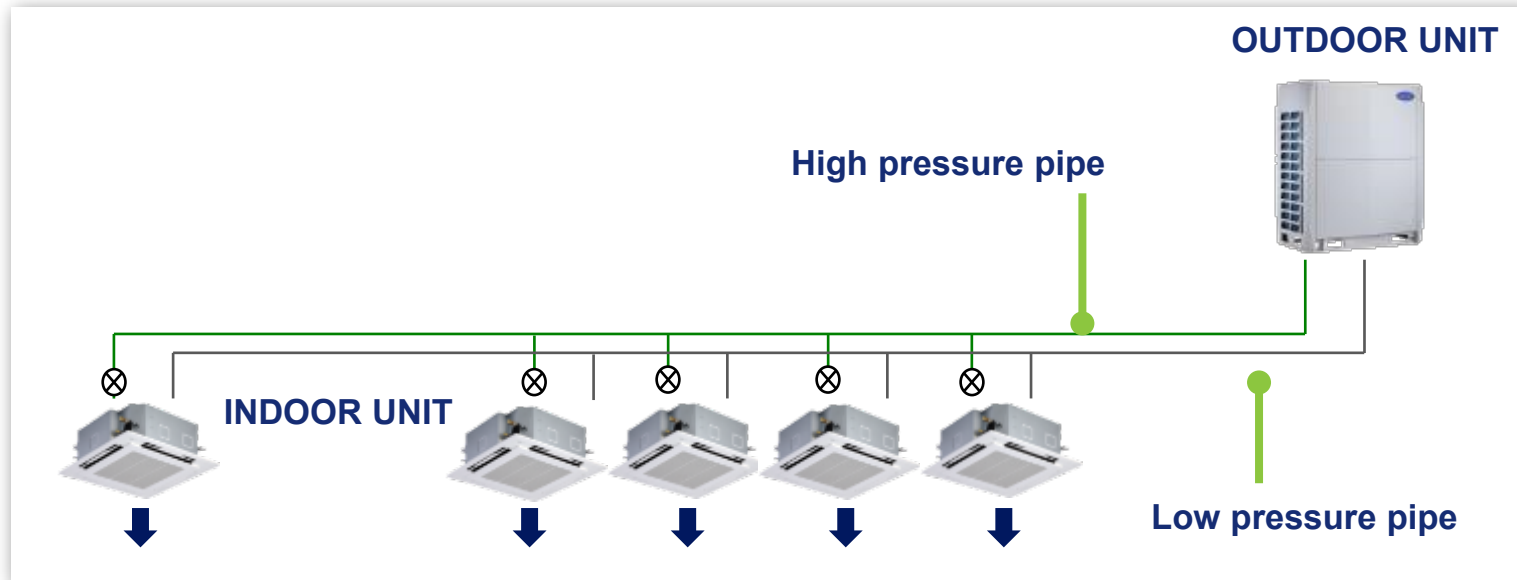

Each Indoor Unit can control the following:

- On/Off
- Set Point
- Air Volume
- Louver Position

Cooling: Expansion at Indoor Unit

Heating: Expansion at Outdoor Unit



INSTALLATION

- Unit placement
- Piping
- Refrigerant addition
- Electrical
- Sizing and connection



INSTALLATION (PIPING OVERVIEW) VROOM

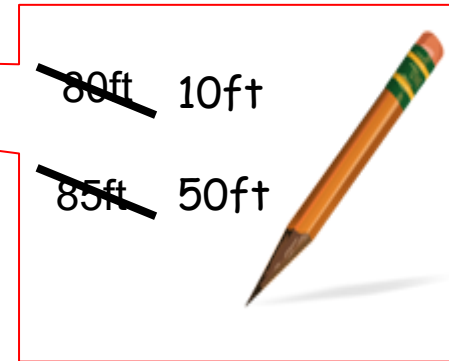
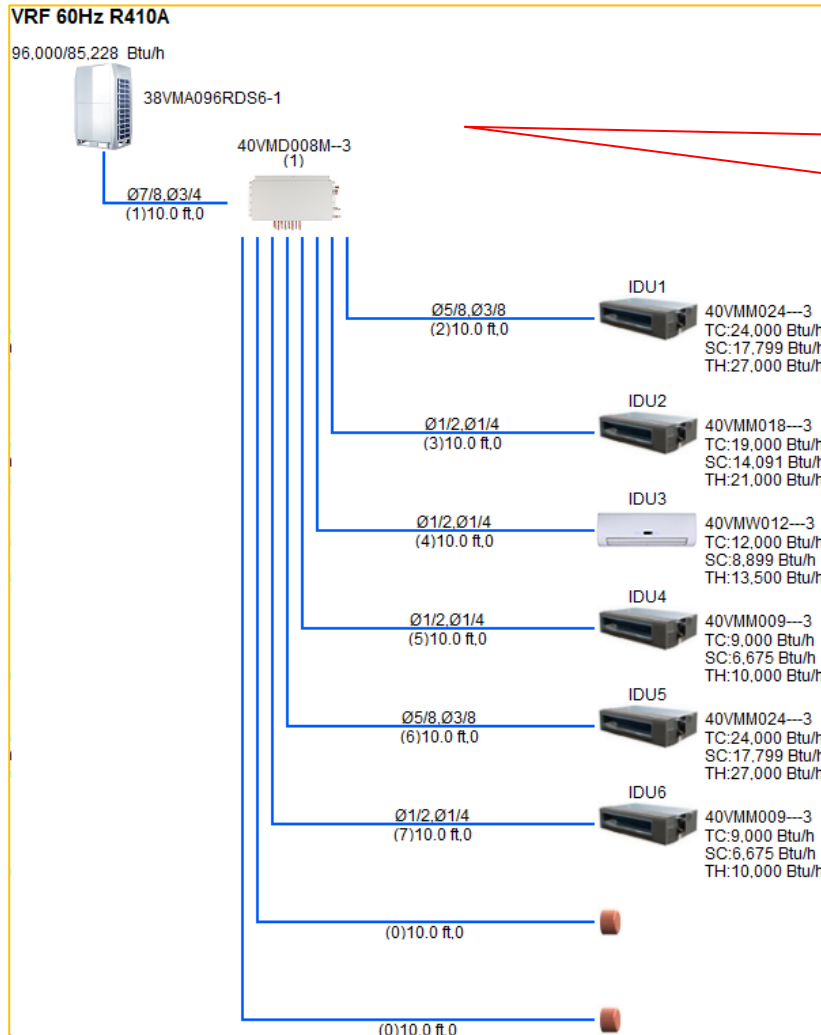

Liquid & Gas Diameters

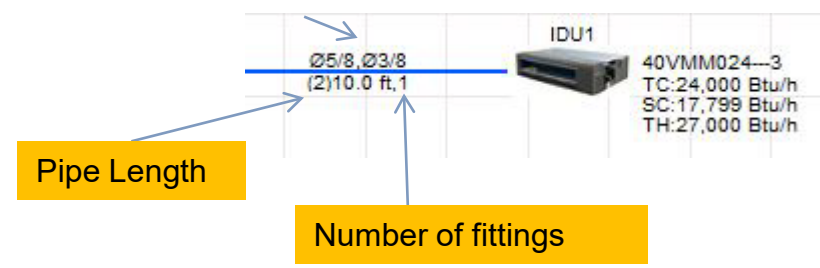

INSTALLATION

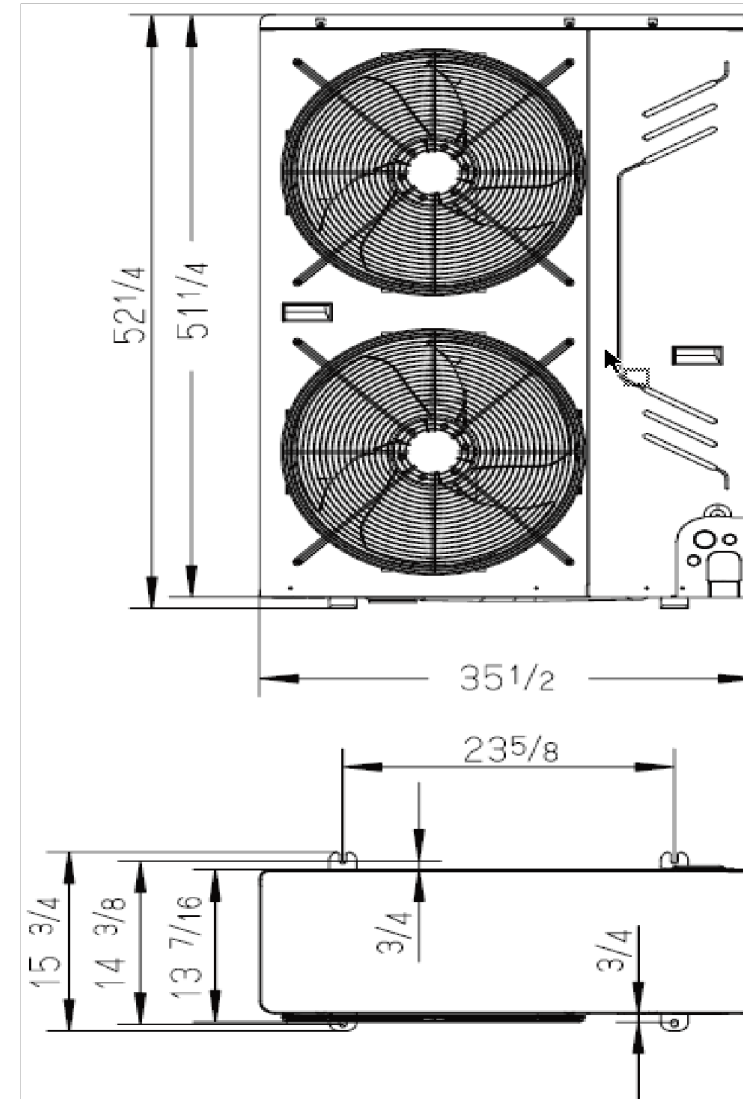
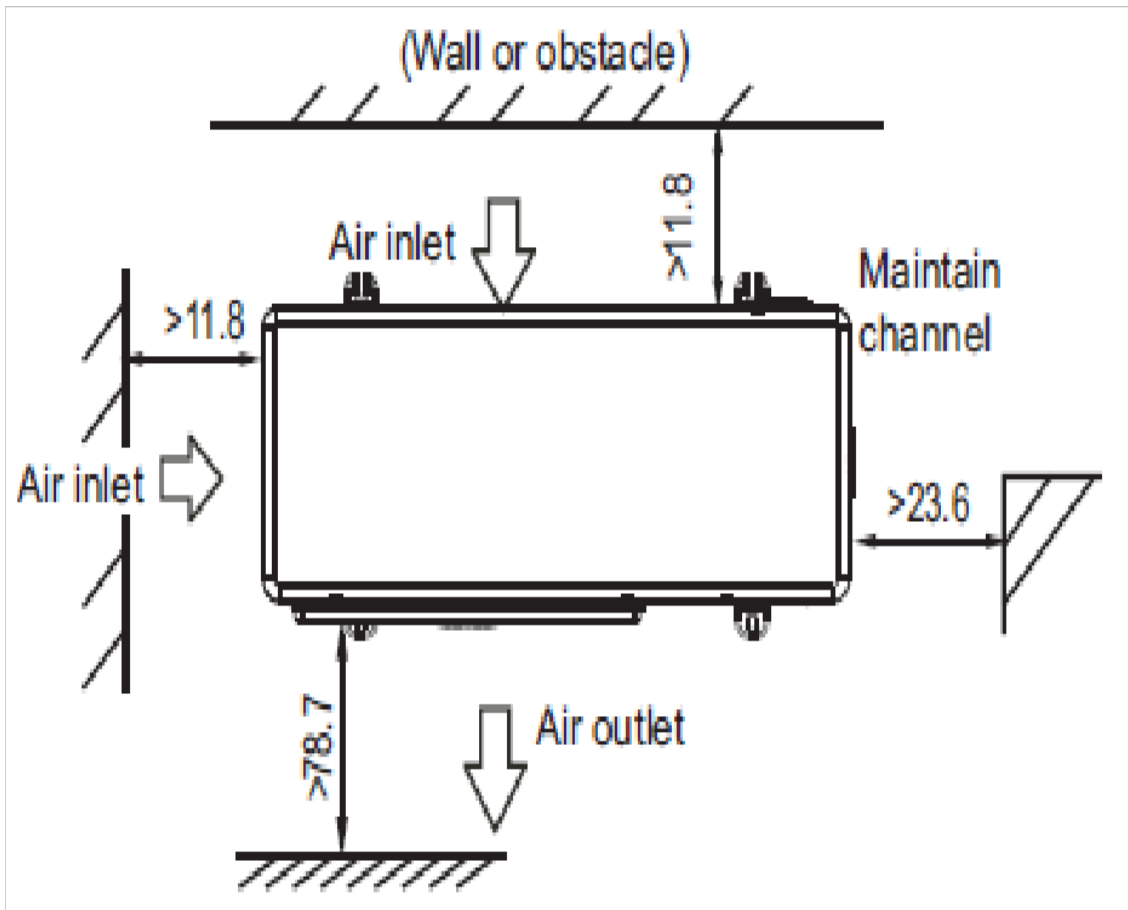

INSTALLATION

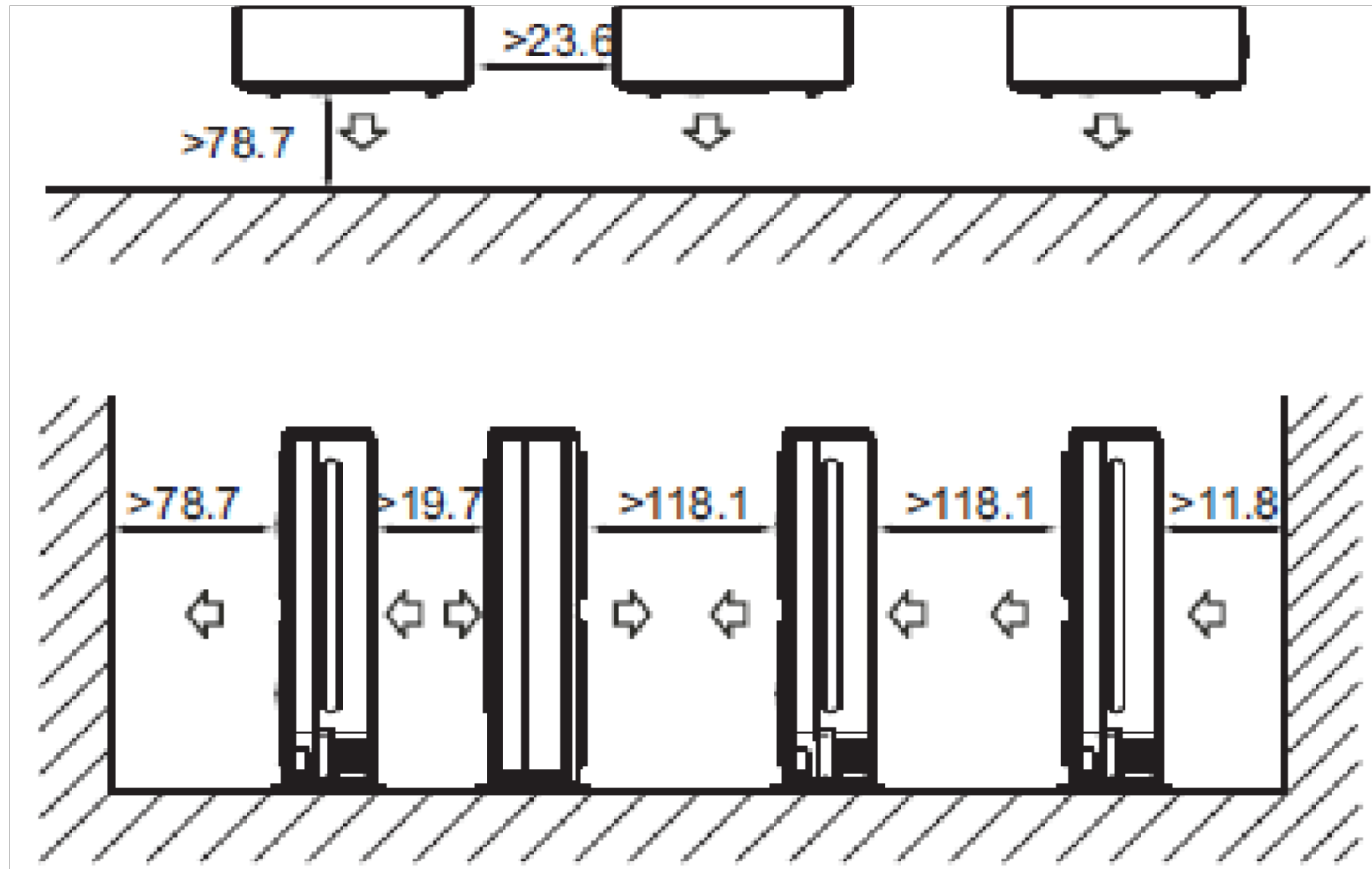

Fig. 5 — Lifting the Unit

CONCRETE BASE REQUIREMENTS

- The unit's base must be made of solid concrete.
- Ensure that the base is level and that the weight of the unit is distributed evenly. See Fig. 6 below for reference.

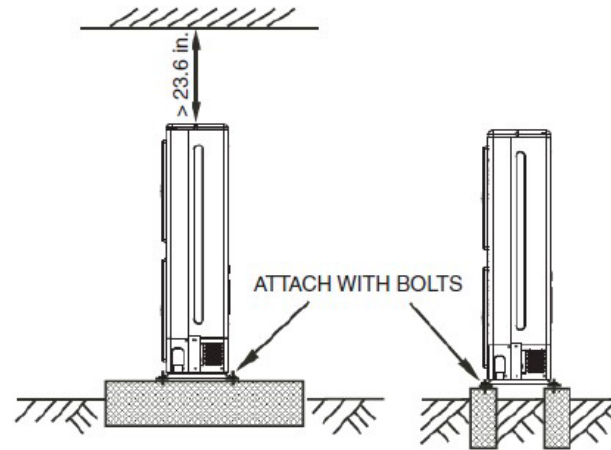
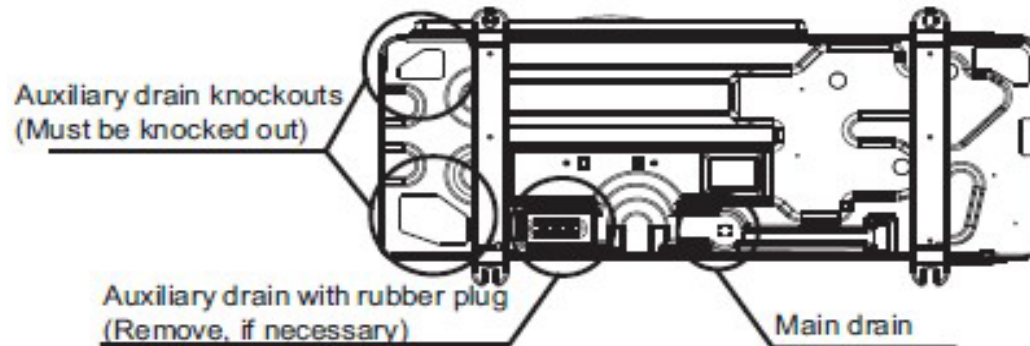



Fig. 6 — Concrete Base

- Create an outlet near the base for drainage. Refer to Fig. 7 below for main drain connection.



036	5	Connected capacity 50 to 130%
048	7	
060	9	

Maximum number of indoor units and connected capacity range per 38VMA outdoor unit.

	CAUTION	
<p>During brazing, keep nitrogen in pipes to avoid oxidation inside the pipes. Use soapy water or refrigerant leak detector to verify every joint in the refrigeration piping.</p>		

INDOOR UNIT SIZE (Btuh)	SUCTION SIDE (in.)	LIQUID SIDE (in.)
7,000 to 15,000	1/2	1/4
18,000 to 48,000	5/8	3/8

38VMH UNIT	CAPACITY (tons)	MAIN PIPE SIZE	
		SUCTION SIDE (in.)	LIQUID SIDE (in.)
036	3	5/8	3/8
048	4		
060	5	3/4 *	



PIPING INSTALLATION

Piping Design

Case 1

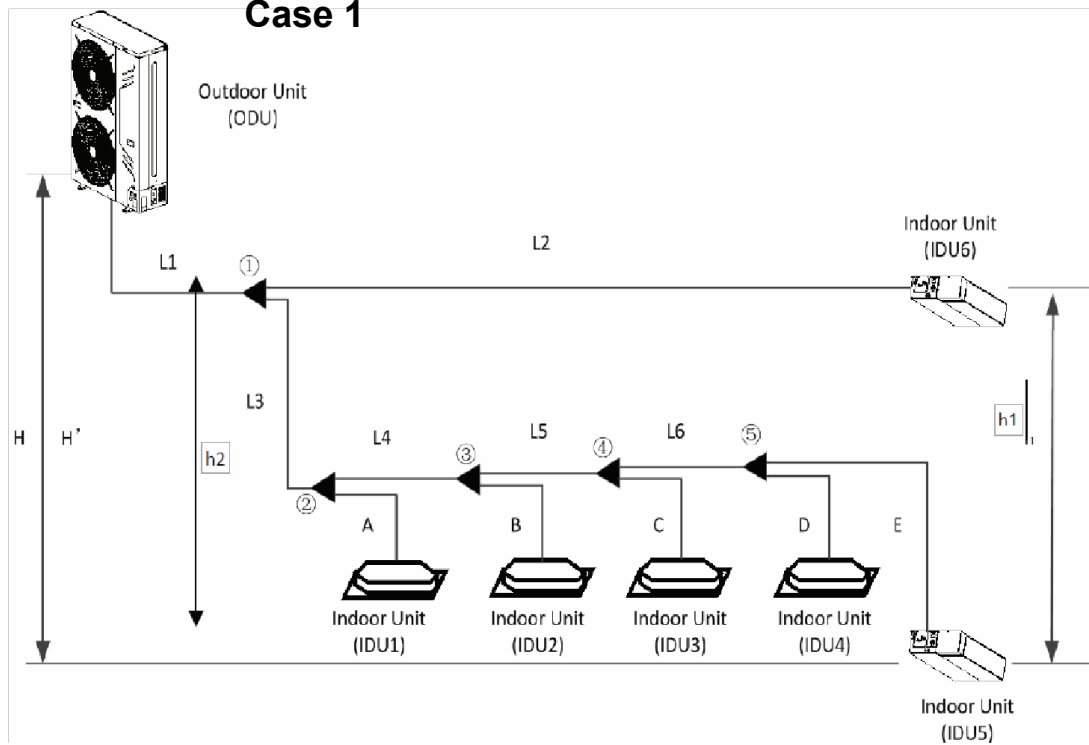

Case 2

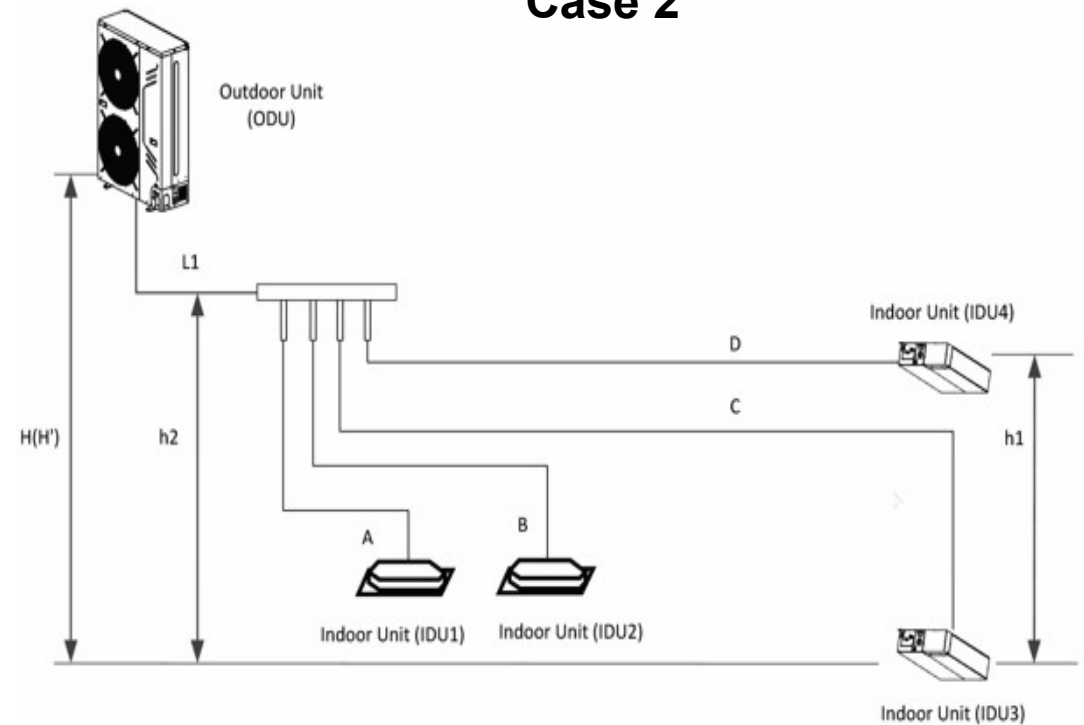

BRANCH JOINT INSTALLATION — The branch joint must be installed parallel to the ground; the angle of the joint should not be greater than 10 degrees. Positioning the branch joint more than 10 degrees from parallel can cause malfunctions. See Fig. 12 for correct positioning of the joint.

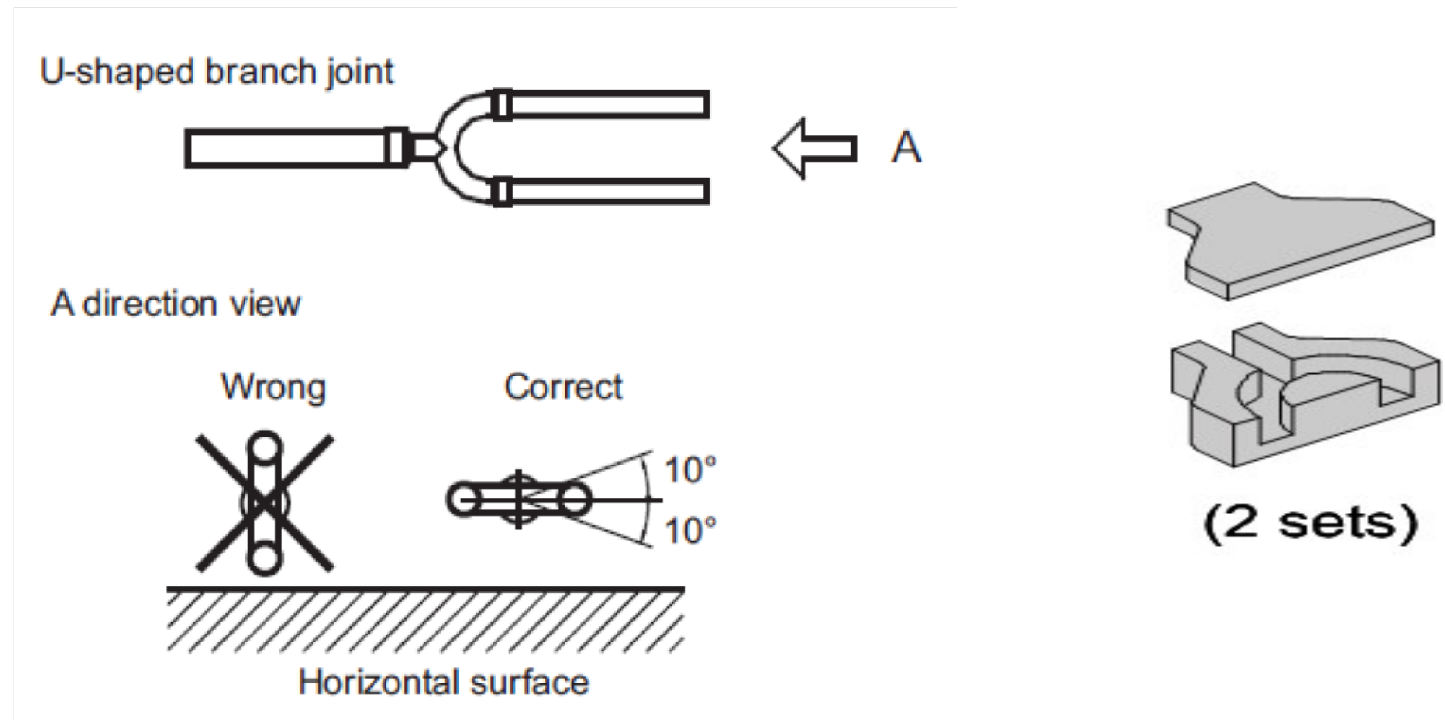

Part Number	Low Pressure Gas Side Joint	Liquid Side Joint
40VM900025	<p>(I. D.) ϕ5/8</p> <p>2-1/2</p> <p>8-3/4</p> <p>(I. D.) ϕ13/16</p> <p>17-1/2</p> <p>2-1/2</p>	<p>(I. D.) ϕ3/8</p> <p>2-1/2</p> <p>9-3/4</p> <p>(I. D.) ϕ3/8</p> <p>18</p> <p>4-1/4</p> <p>2</p>

CONNECTION AND CENTERING

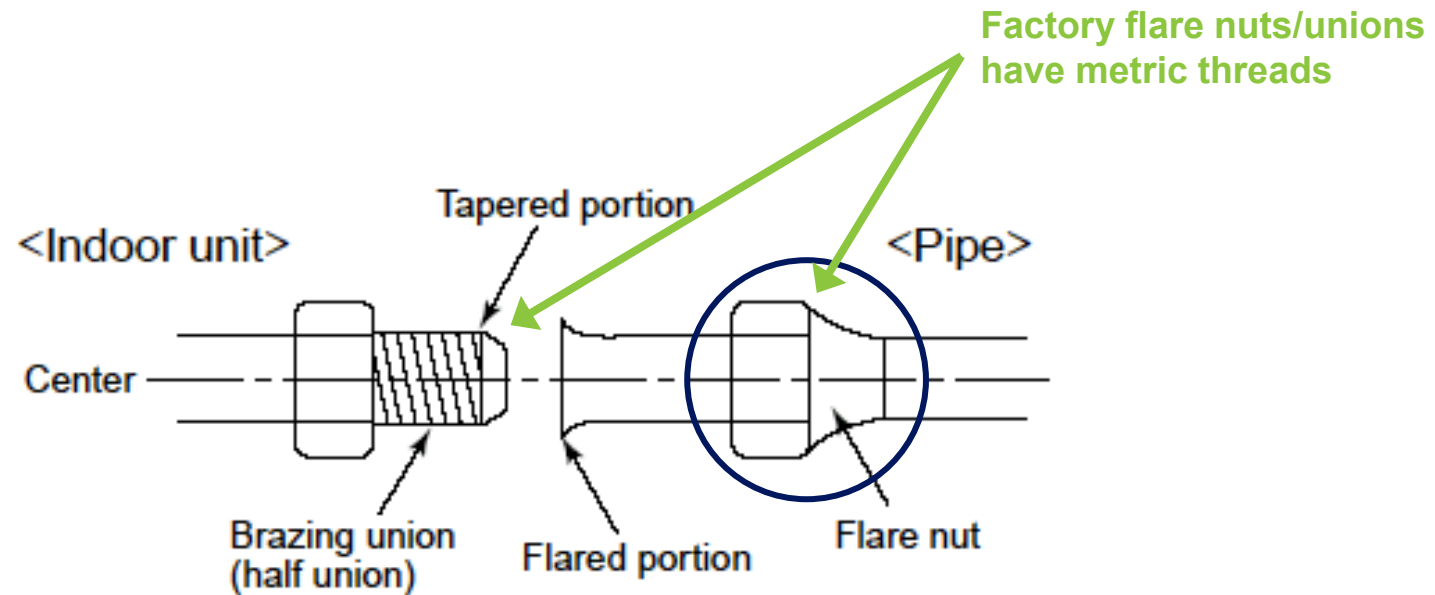

Flare is standard 45-degree flare used for R-410a

WHY A DEDICATED R410A FLARING TOOL?

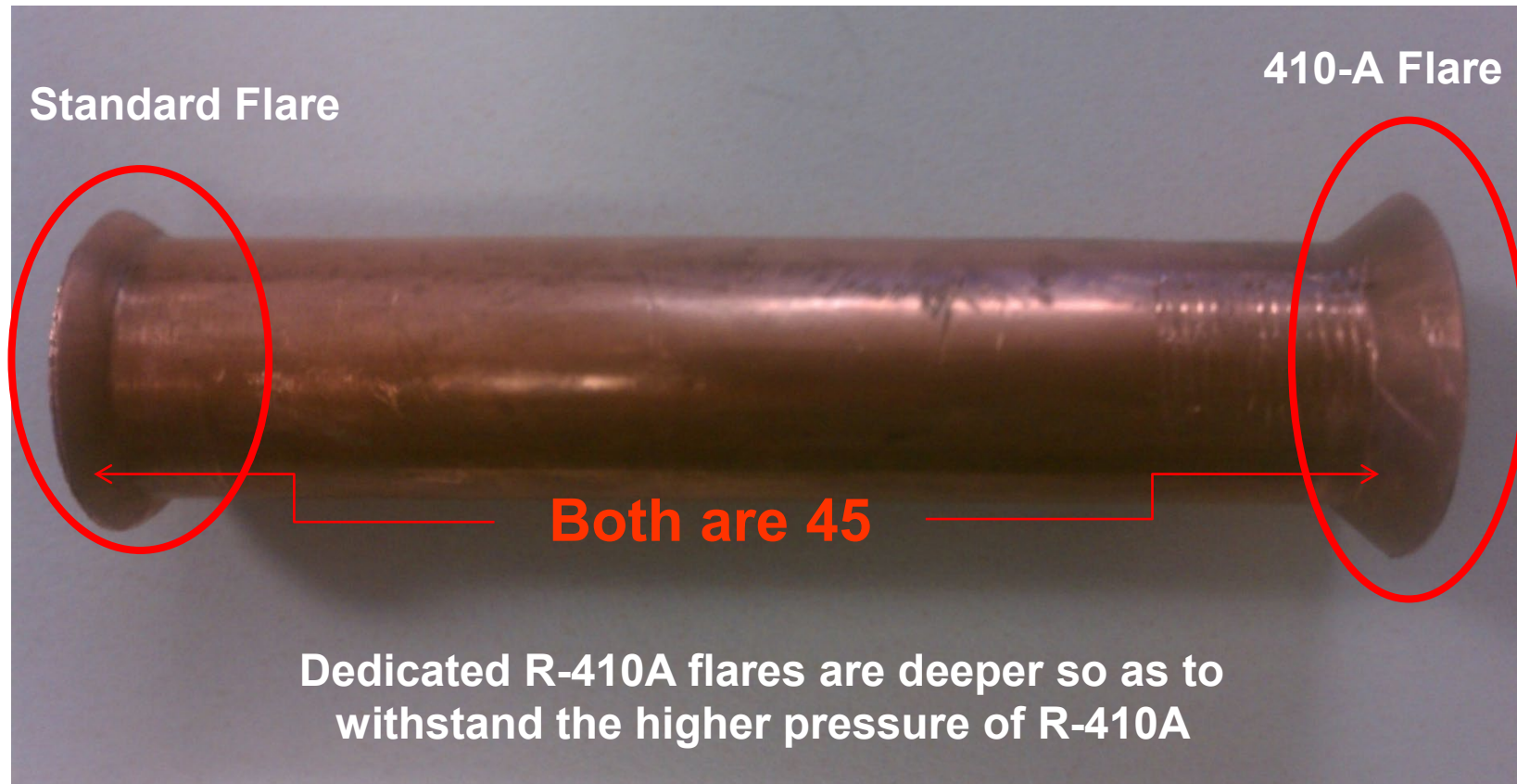

WHY A DEDICATED R410A FLARING TOOL?

✓ R-410a Flaring Tool



R410A systems operate at high pressures

- The clutched handle prevents the crushing of the copper tube at the point of the flare. This helps maintain the strength and integrity of the copper tubing so it will withstand the higher operating pressures.
- The concentric cone helps make a uniform flare and reduces the thinning of the tube wall, this also eliminates the need of oil on the inside of the flare which can result in contamination and acid formation within the operating system.

TIGHTENING THE FLARE NUT

Connecting Pipe Outer Dia. (in)	Ft-lbs.
Ø1/4"	10 to 13
Ø3/8"	24 to 31
Ø1/2"	37 to 46
Ø5/8"	50 to 60



Torque wrench

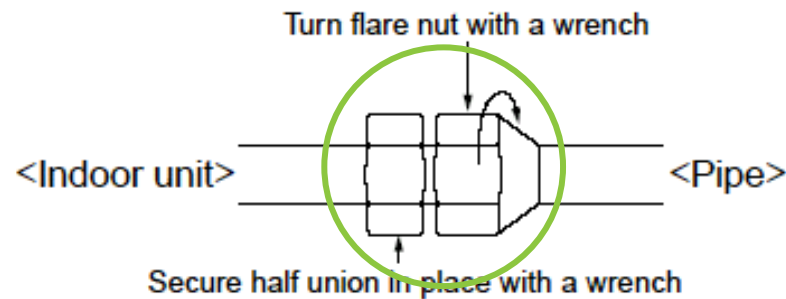

Be sure to always use a backup wrench

Purge Rate of 1.76
Cubic Feet Per Minute





INSULATION AND CONDENSATE

INSULATION GUIDELINES

When insulating a supported section:

Ensure pipe is insulated fully. Some support systems will require clamp to be insulated.

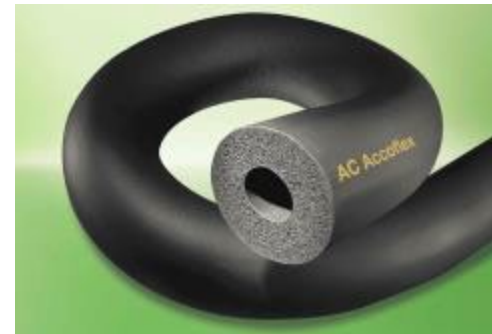
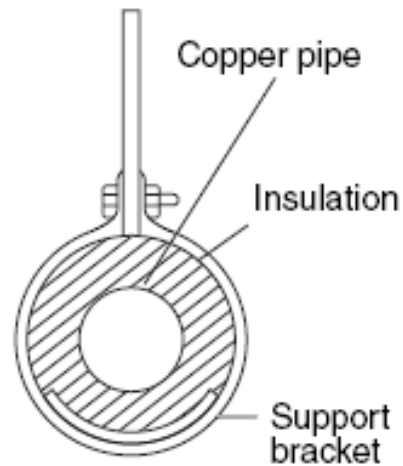

DRAIN PIPING ERRORS

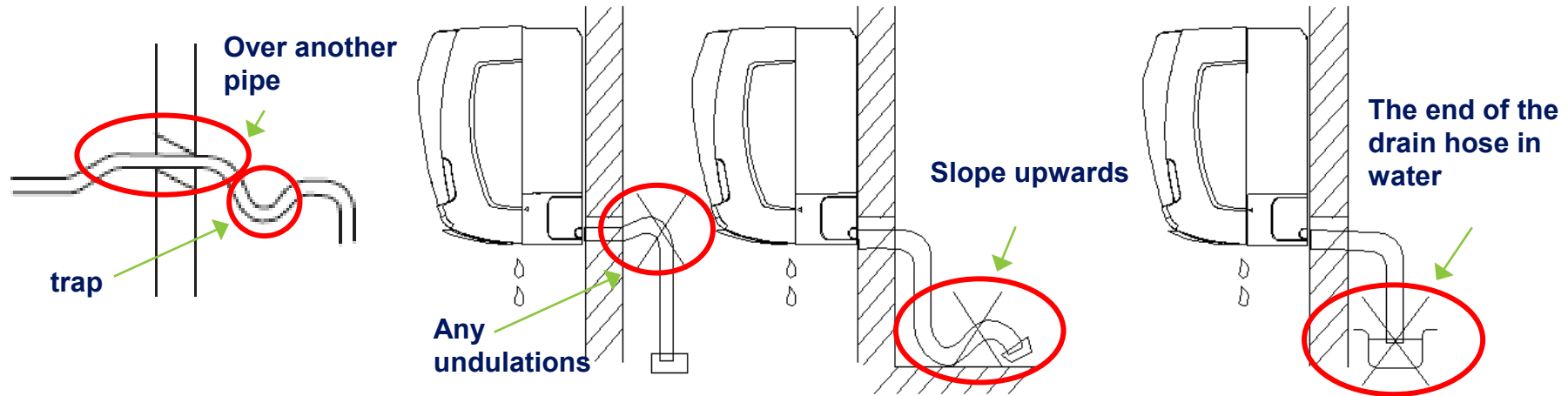

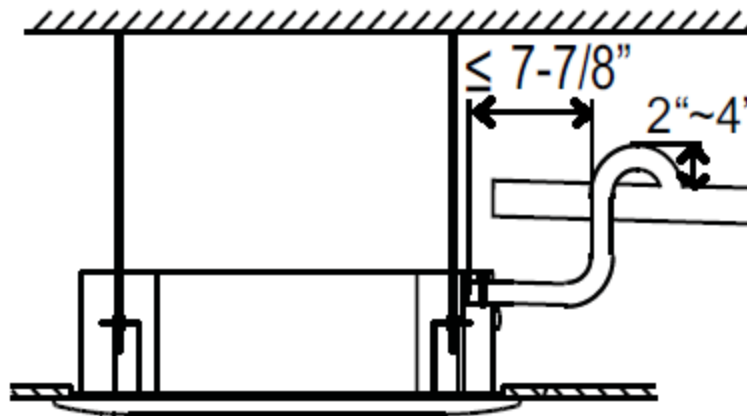
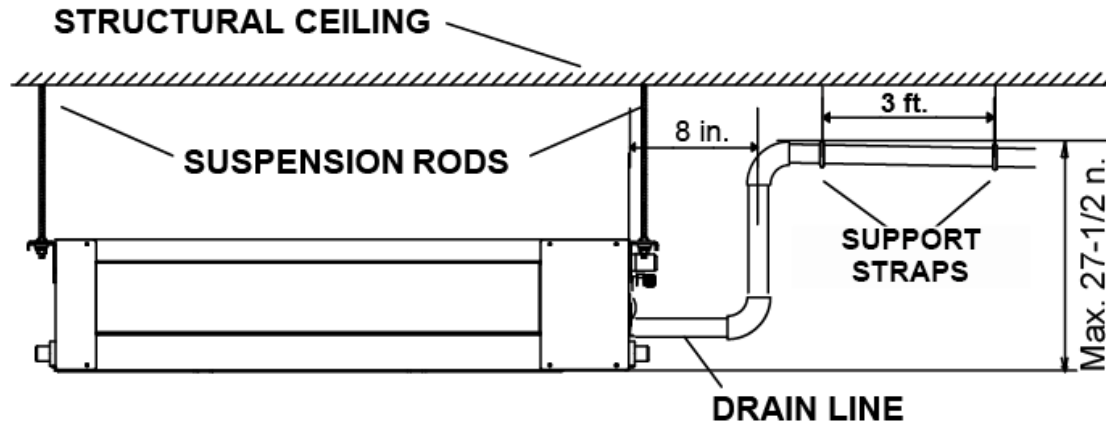

If not kept, drain over flow trouble may occur!



ELECTRICAL

POWER SUPPLY TERMINAL BLOCK

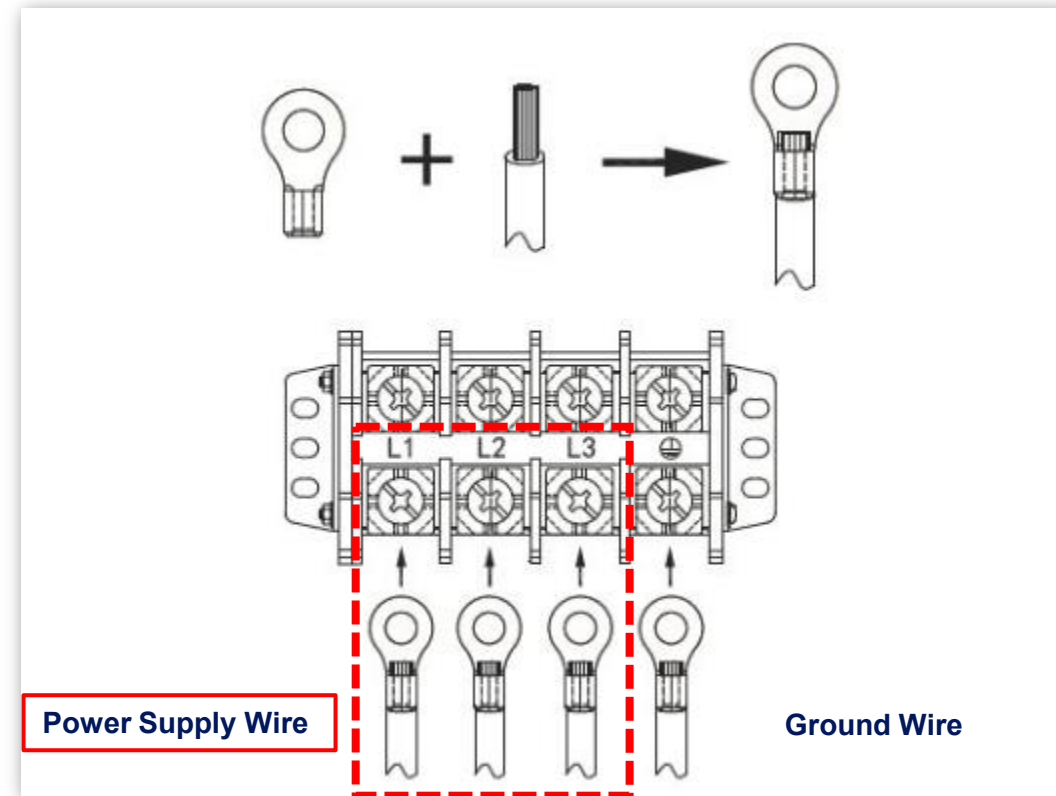
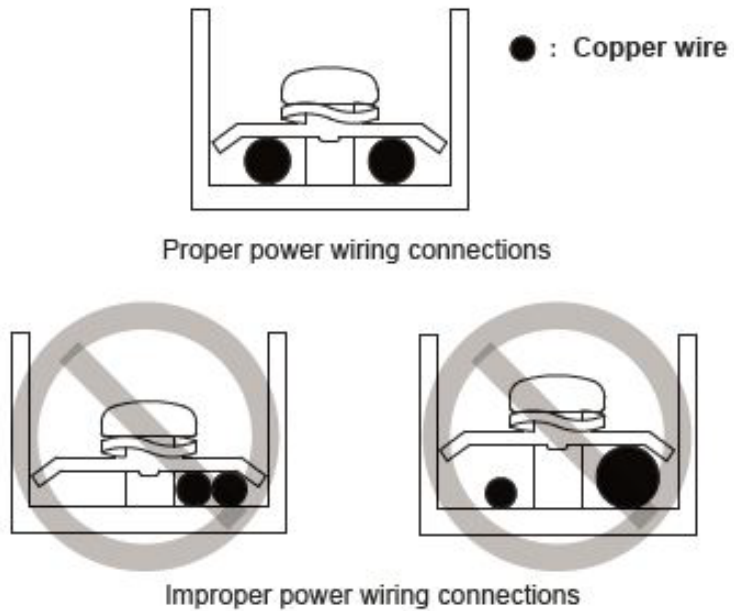

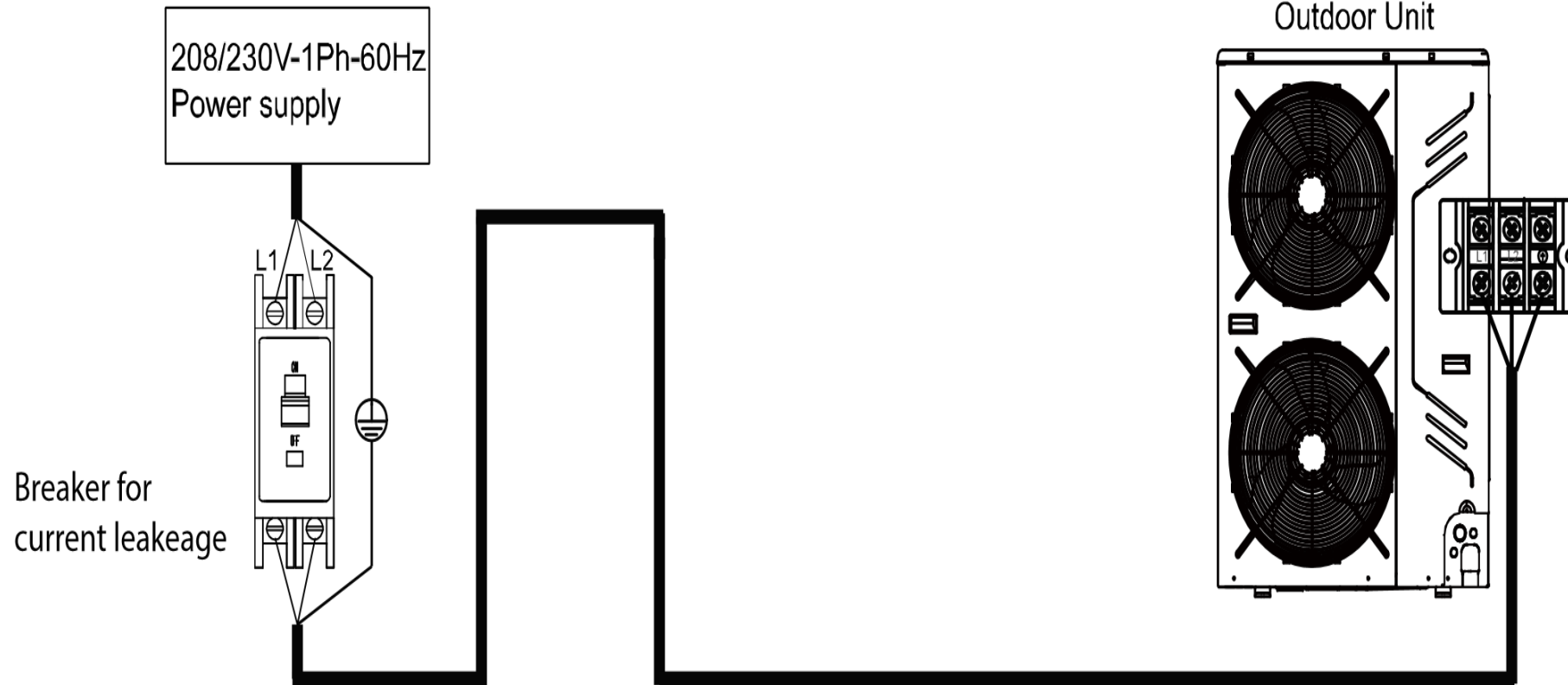

Indoor units can share same power supply

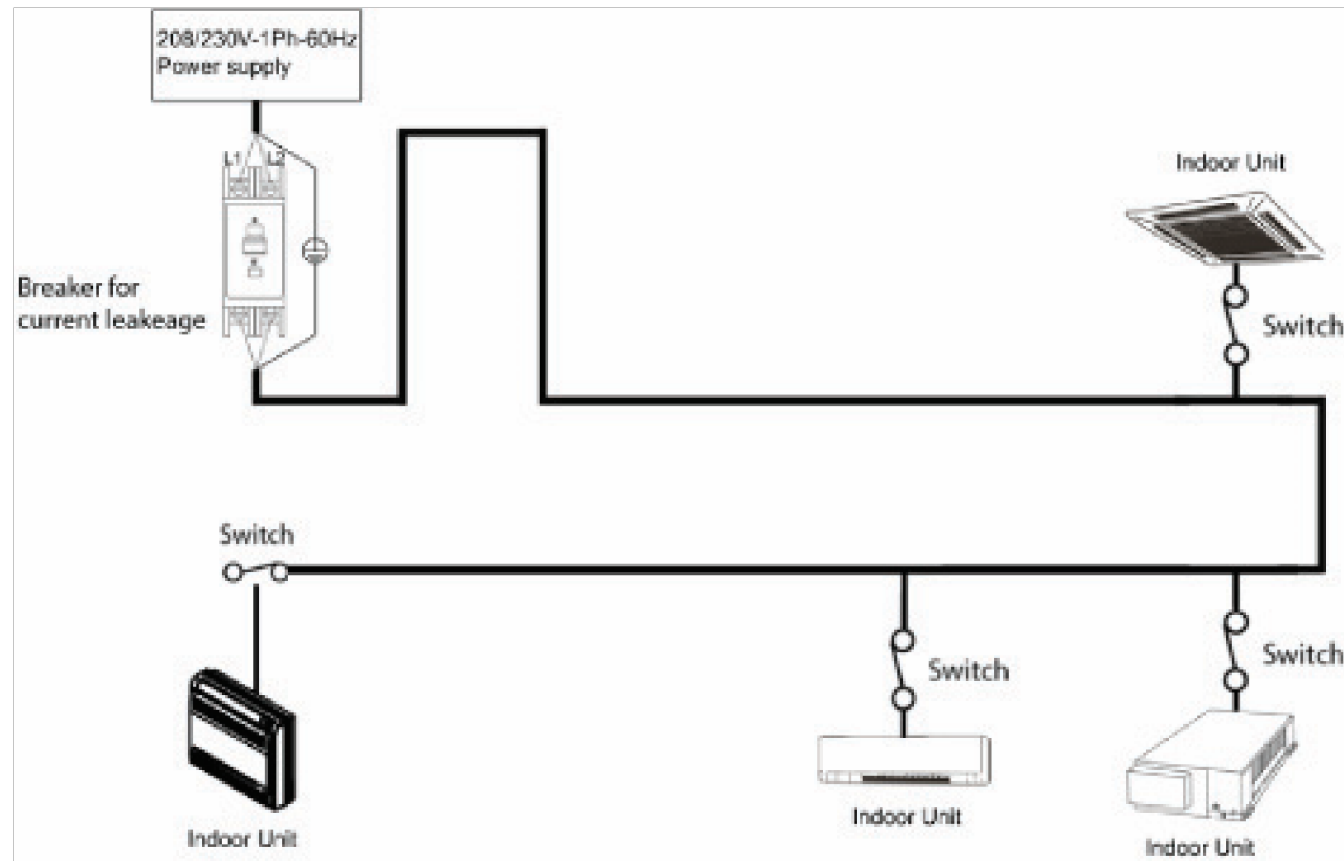

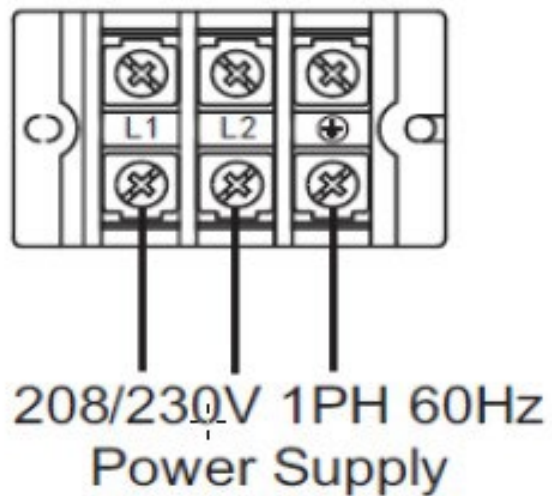

IMPORTANT: Wiring for communication shall be 2 inches. or more apart from power source wiring to avoid electric noise. Do not insert control/communication and power source wire in the same conduit.

Pay attention to the polarity of communication wire.

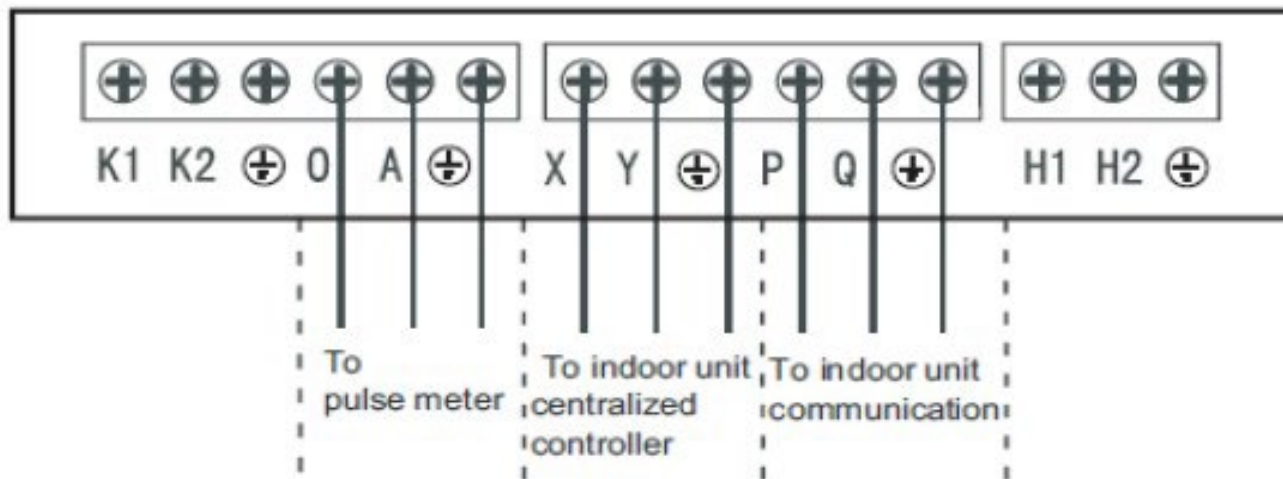

Outdoor Unit Communication Port Diagram

COMMUNICATION CABLE — The type of communication cable used is a 2-core stranded shielded cable. The diameter of the wire should be AWG 16. The maximum wire length cannot exceed 3,937 feet between outdoor and indoor units and less than or equal to 820 feet between the wired controller and indoor units. Communication wires are sold separately.

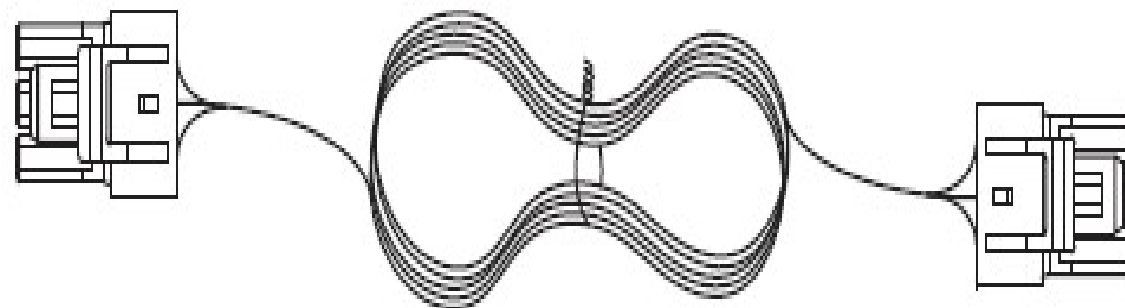

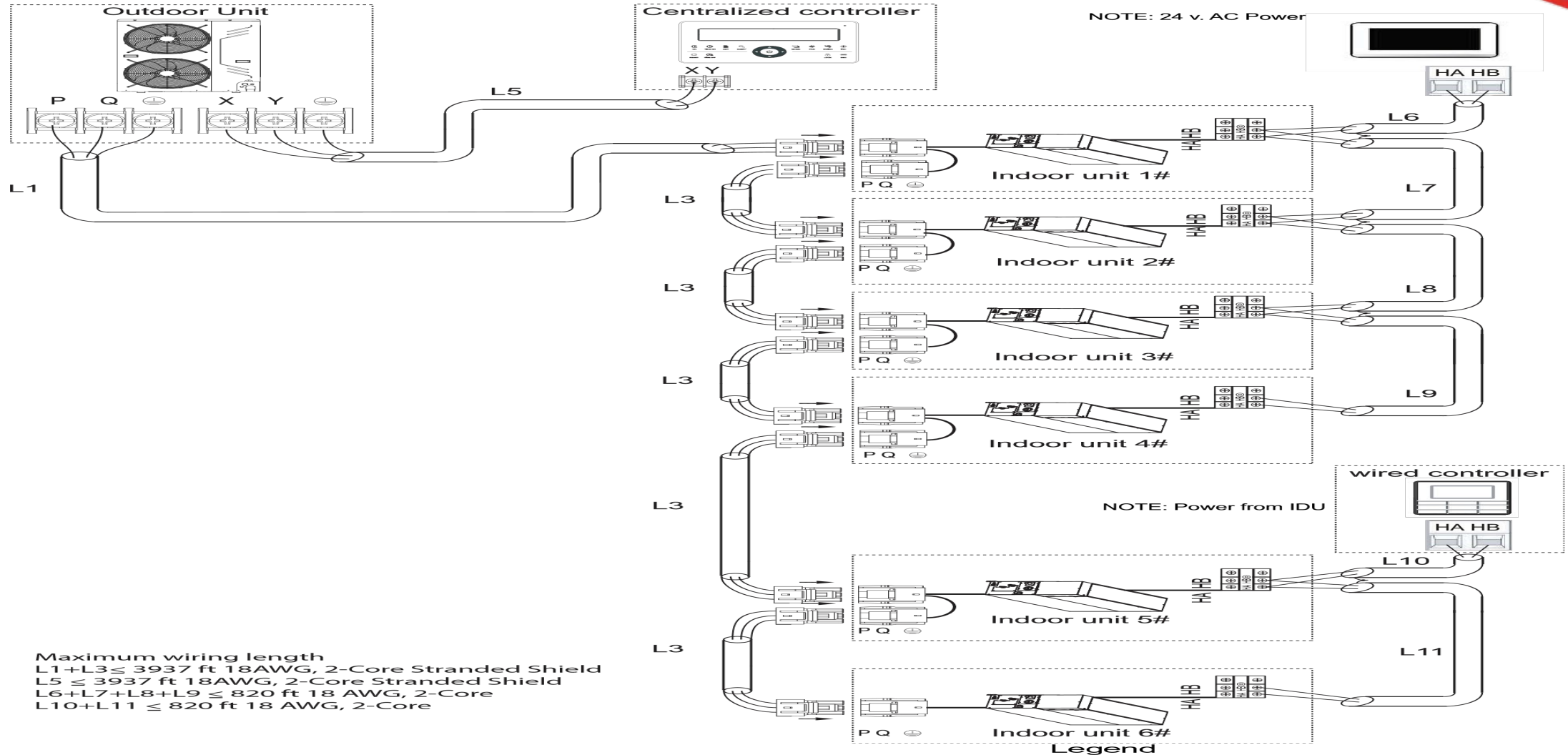

Maximum wiring length
 $L1+L3 \leq 3937$ ft 18AWG, 2-Core Stranded Shield
 $L5 \leq 3937$ ft 18AWG, 2-Core Stranded Shield
 $L6+L7+L8+L9 \leq 820$ ft 18 AWG, 2-Core
 $L10+L11 \leq 820$ ft 18 AWG, 2-Core

ENHANCE STABILITY OF COMMUNICATION

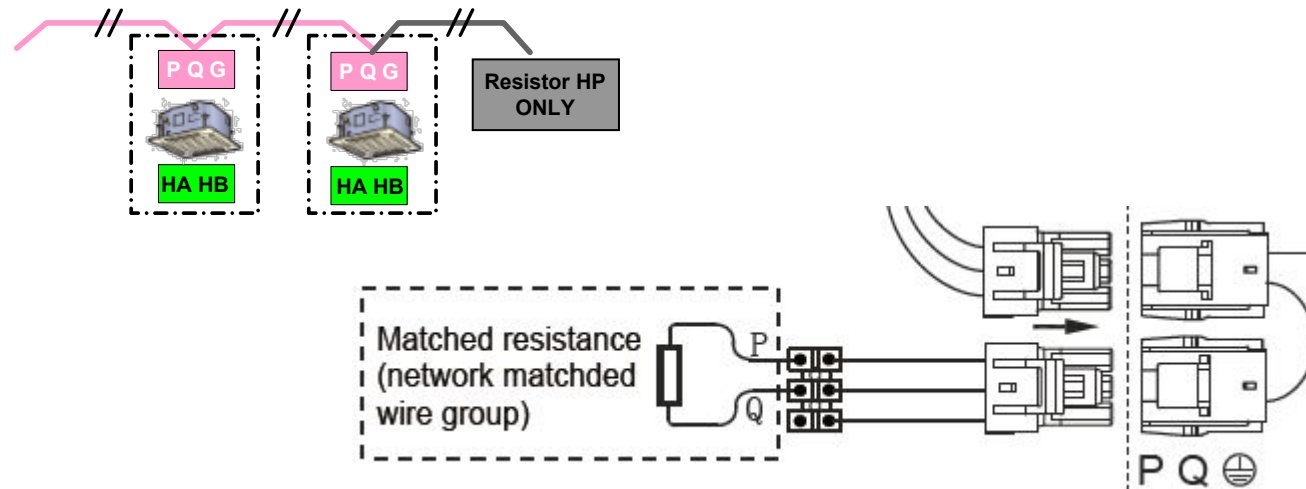

Please connect this 120 ohm resistor located in the outdoor unit accessory bag to the last IDU.

CONNECTION OF REMOTE CONTROL

Individual Control

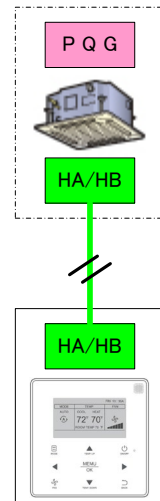

Terminal block for remote controller wiring in indoor unit

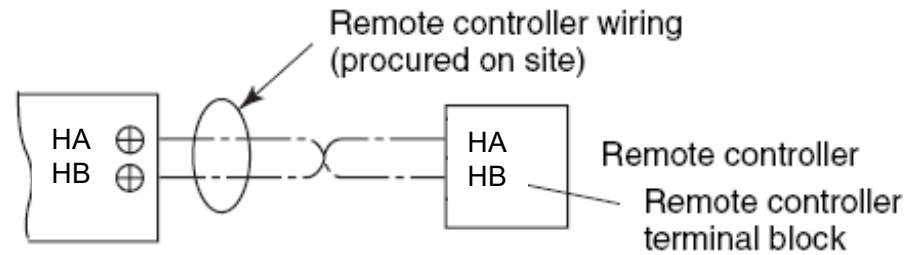

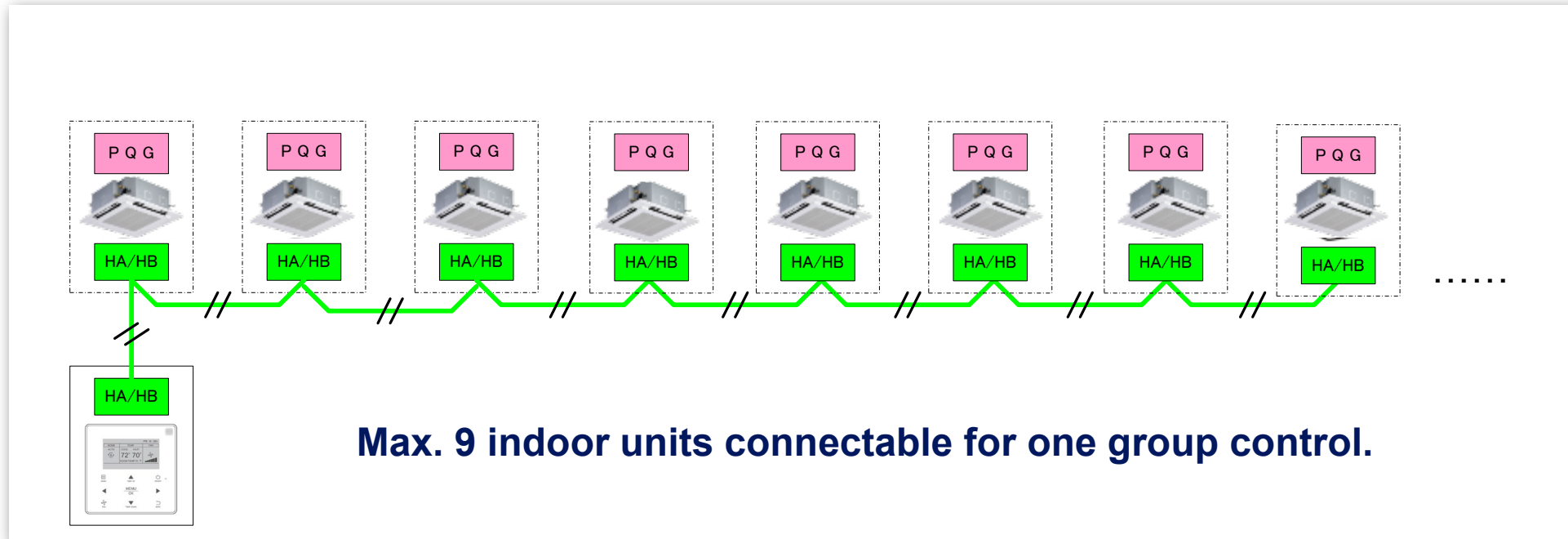

Terminals A and B are 2-core non-polarity



DIP SWITCH SETTINGS

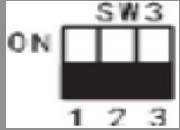
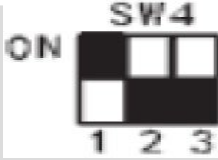
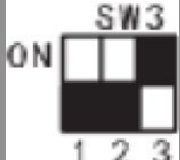
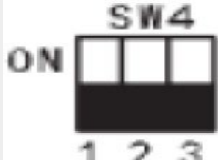
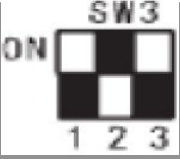
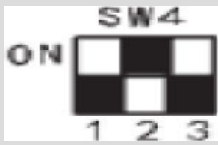
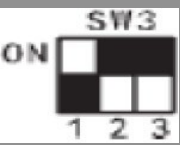
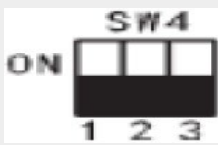
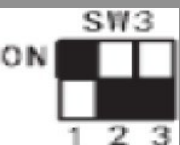

SW3 Function Definition		SW4 Function Definition	
	Heating priority mode		Automatic addressing
	Cooling priority mode		Non-automatic addressing (factory default)
	First running priority mode		Clear IDU address
	Heating mode only		Fahrenheit temperature (factory default)
	Cooling mode only		Celsius temperature



ENC2 Function Definition



ODU network
address dial-up
Only 0-7 used

BOARD LAYOUT

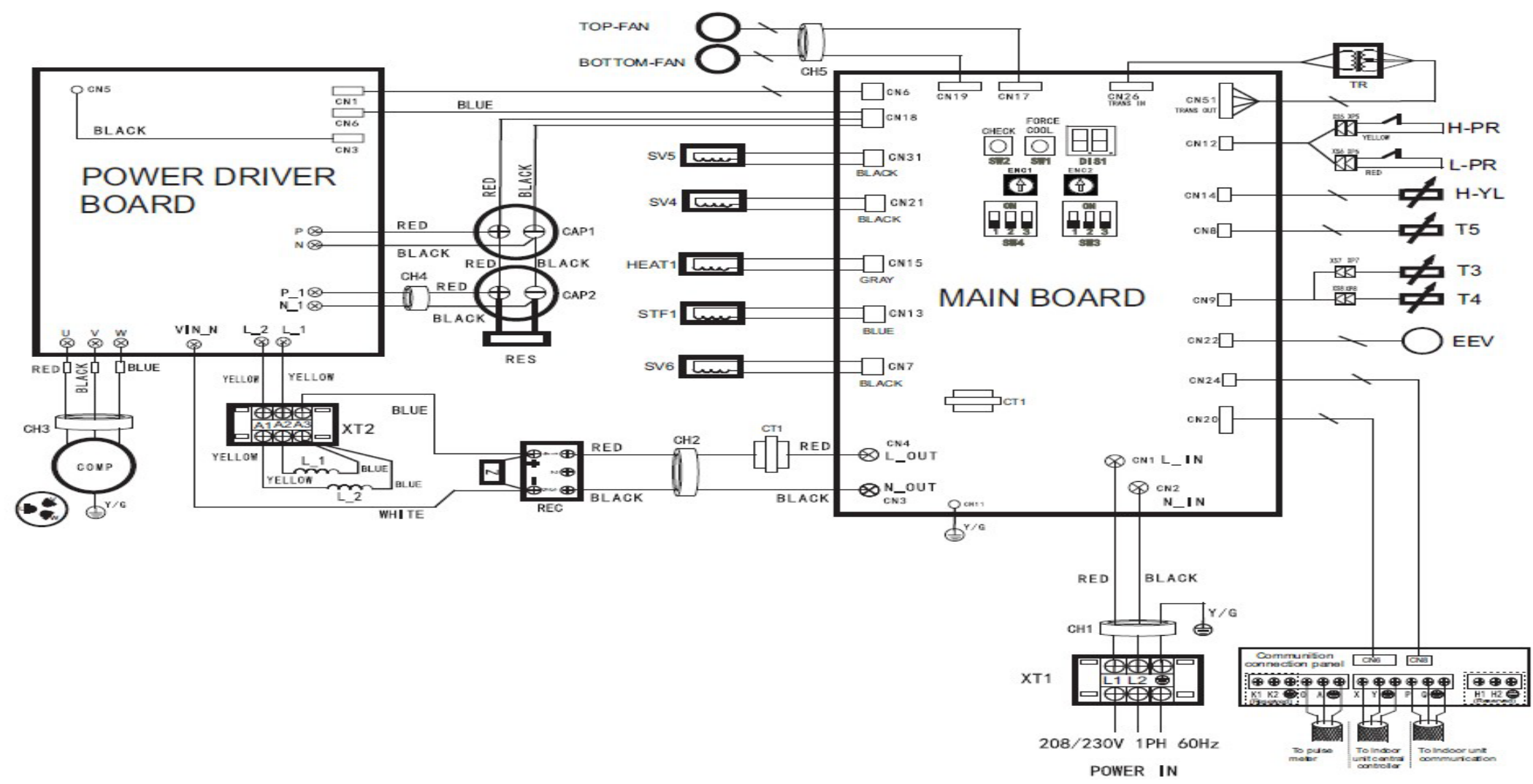

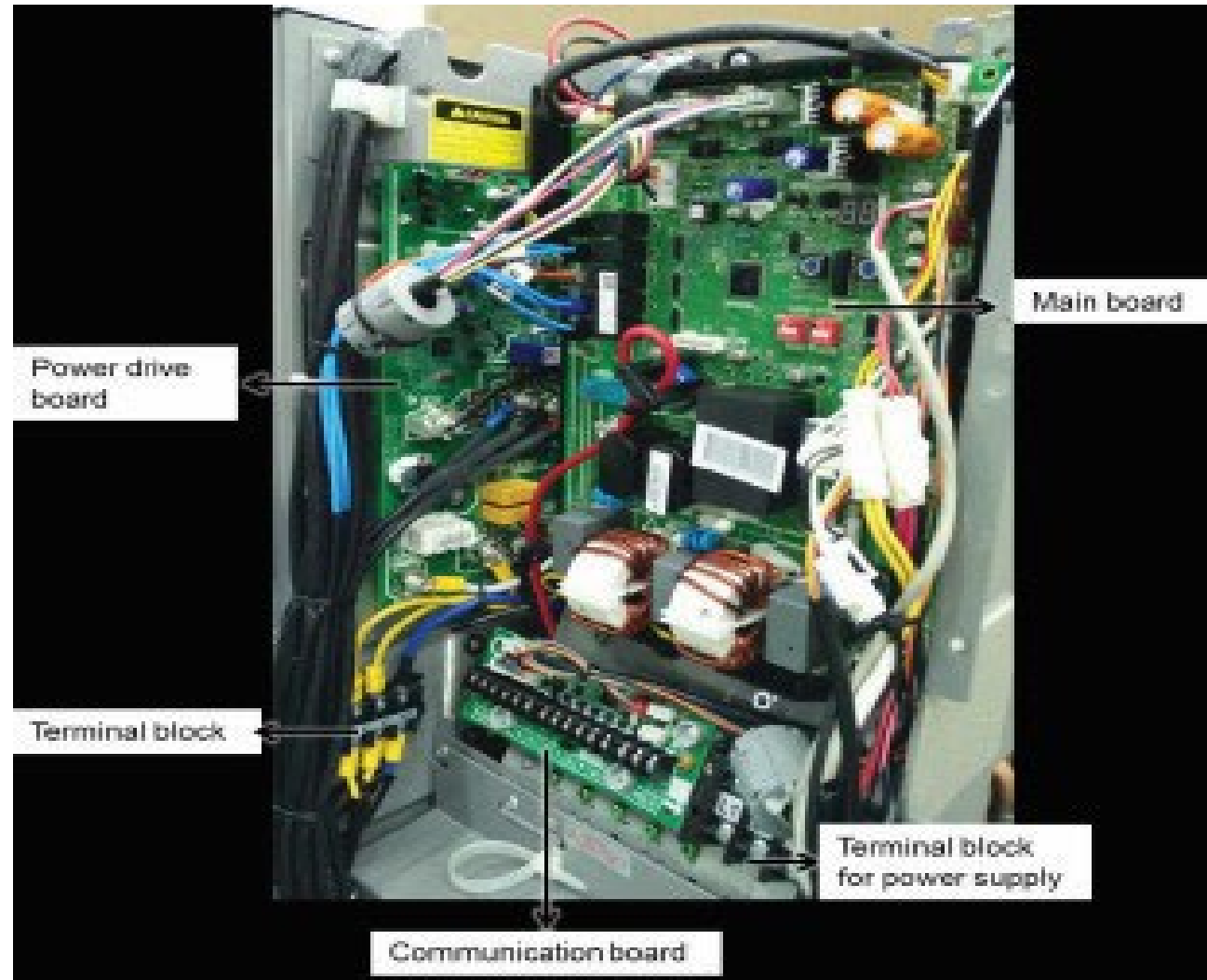

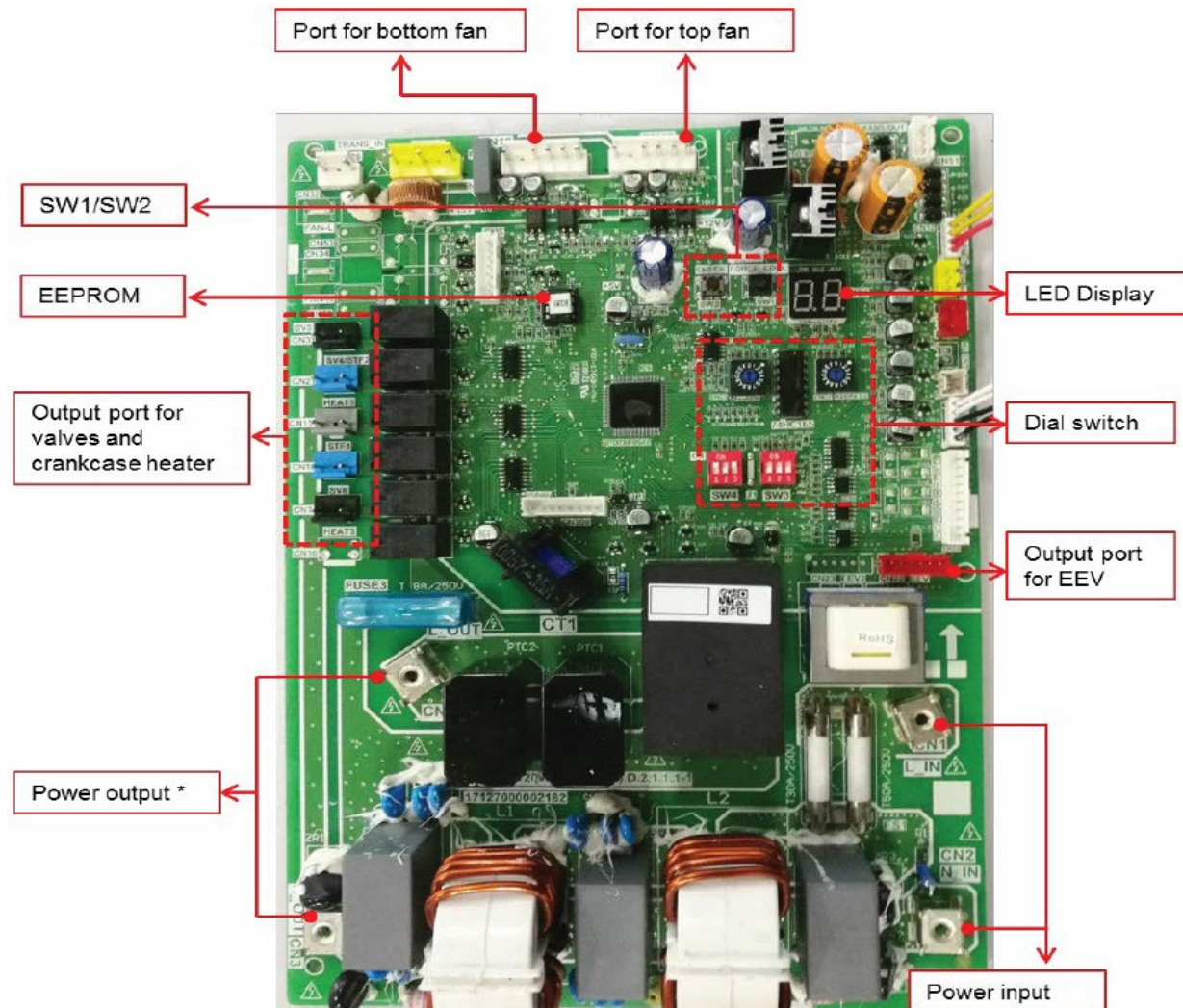



Leak Test

Step 1	50psi	at least 3 minutes	FOR LARGE GAS LEAKS
Step 2	200psi	at least 3 minutes	FOR LARGE GAS LEAKS
Step 3	500psi	at least 24 hours	FOR SLOW GAS LEAKS

The pressure will change by approx. 2.6psi per 1 deg. F.

@ record time & temperature

@ compare start test data and adjust by temperature difference

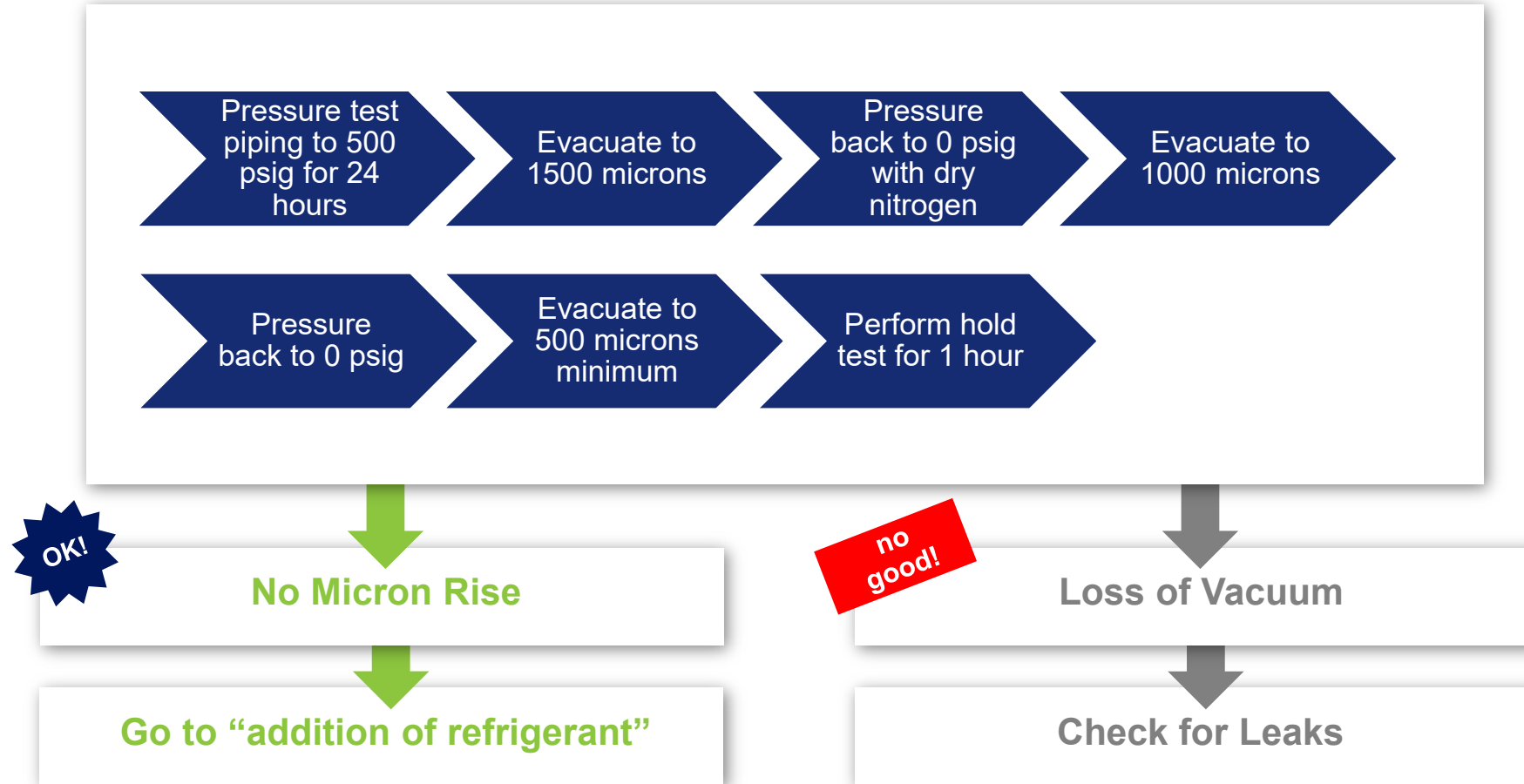

Additional Refrigerant Charge in Field

How to calculate

$$\boxed{\text{Actual length of liquid pipe}} \times \boxed{\text{Additional refrigerant charge per liquid pipe 1ft}} = \boxed{\text{Additional refrigerant charge per liquid pipe 1ft}}$$

Calculate the added refrigerant according to the diameter and the length of the liquid side pipe of the outdoor/indoor unit connection.

Liquid pipe diameter (in)	Additional refrigerant amount (lb/ft)
1/4	0.015
3/8	0.040
1/2	0.080
5/8	0.120
3/4	0.181
7/8	0.255



PRE START UP

CAUTION

Prior to System Start up ensure that the system has had power energized for at least 24 hours



Pre Start Check

- Verify that the power and phase requirements are correct and both legs are present.
- Check that the power source's voltage is within 10% of the rated voltage.
- Check and confirm that the power and control wire are correctly connected.
- Check that all units have passed a nitrogen pressure test for 24 hours.
- Provide the customer accurate "as-built" drawings and documents, including actual piping lengths and locations, unit addresses, settings, etc. this is also important for vroom file and additional charge.
- Ensure additional refrigerant charge calculations are correct and that the system is charged accordingly.
- Energize outdoor units for at least 24 hours before system start-up to ensure proper oil temperature has been achieved.
- Ensure all refrigerant valves on outdoor units are fully open. If these valves are not fully open, equipment damage may occur.

- Set dipswitch SW4 Bit 1 on for auto addressing.
- Set network address ENC2 (if more than one outdoor unit)
- The next slides illustrate how to manually address the IDU's

STEP 1



Use tool to press and hold the “LOCK” button for more than 10se and press button to activate

STEP 2

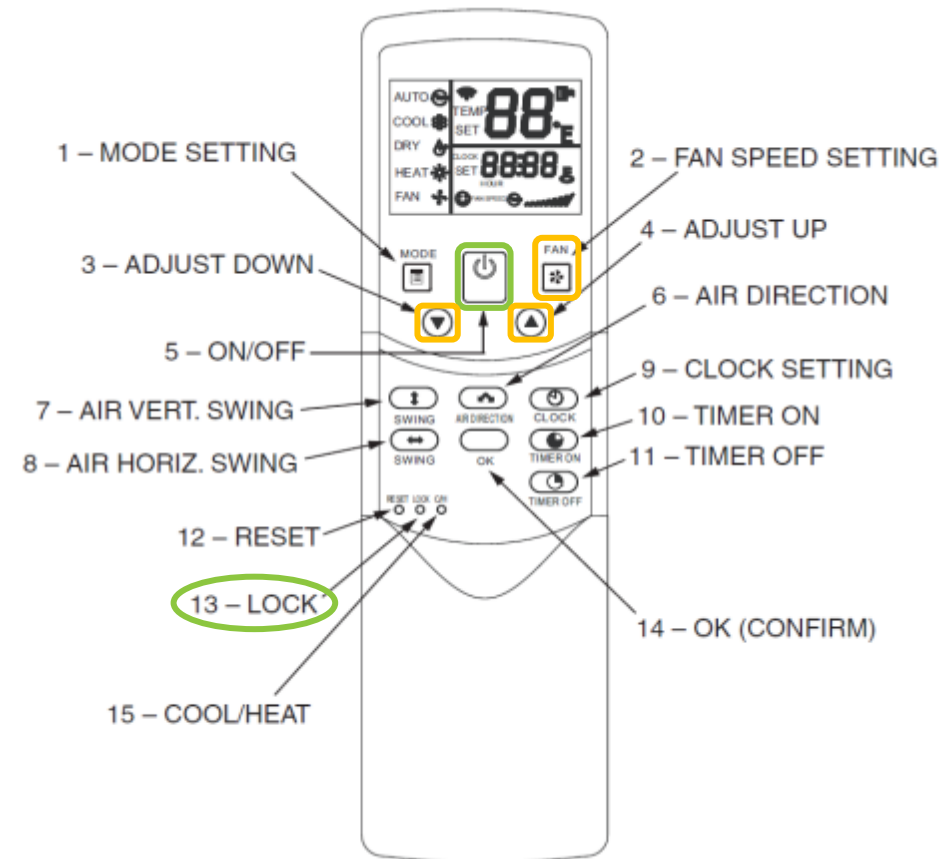

Click or to select an address you want to set and press to send the setting.



STEP 1

Press  and  together for 5 seconds and It displays FE# 00 if there is no address for this indoor unit, otherwise displays current address of the indoor unit.

STEP 2

Click  or  to change 00 to address number you want to set. Then press **OK** to confirm and exit the setting interface.

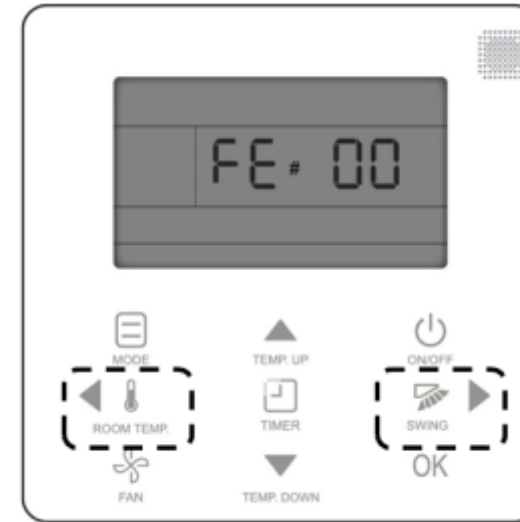

STEP 1

Press and simultaneously for 5sec to enter the interface for parameter settings.

STEP 2

Press or to move the cursor down and choose IDU ADDRESSING, then to enter this setting.

STEP 3

Press or to choose the address No. you want to set, then to send this address to the IDU.

STEP 4

Press twice or wait 30sec to automatically exit the parameter settings menu.

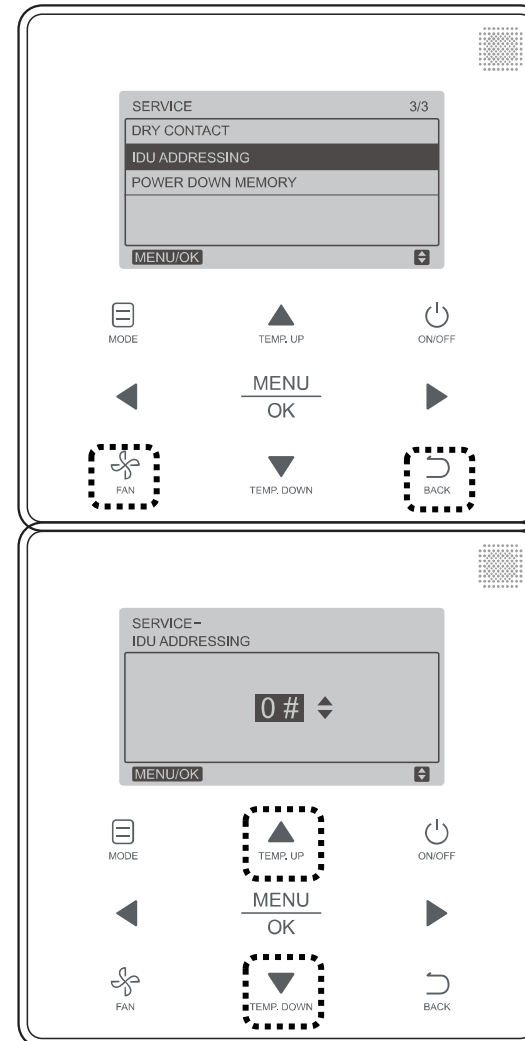

- Where you see the error code is important. Wired controller vs IDU vs ODU. You need to look in the corresponding install and service manual for the location of the error code. This is also true with DLS. The Code you see may not mean the same thing in each manual. This is why it is important to know where you are seeing the code.
- STT is a free software you can get from Mingledorff's. Contact myself at slocicero@mingledorffs.com or your TM to get the software. You will need to purchase a RS485 adapter.

RS485 ADAPTER NEEDED FOR STT



38VMH: 3-Phase Heat Pump x Microsoft PowerPoint - Carrier B x +

Not secure | files.hvacpartners.com/docs/1001/ChanPart/08/CBI-QRG-01.pdf

Microsoft PowerPoint - Carrier Bryant and ICP Quick Reference Guide ... 65 / 90 | 100% + |



STT

Connecting to system - What's Needed

STT Service Technical Tool

USB to RS485 (field supplied)

USB to Micro USB (field supplied)



hvacpartners.com All Products 276k Variable Refrigerant Flow Carrier Units All Products

38VMR Heat Recovery
Carrier VRF
100 Heat Recovery System
20,000 to 150,000 Btu/h
\$1,100.00 - \$2,100.00

Type here to search

47°F Clear 8:12 PM 11/15/2021

RS485 ADAPTER TO XY BUS.



38VMH: 3-Phase Heat Pump x Microsoft PowerPoint - Carrier B... x

Not secure | files.hvacpartners.com/docs/1001/ChanPart/08/CBI-QRG-01.pdf

Microsoft PowerPoint - Carrier Bryant and ICP Quick Reference Guide ... 66 / 90 | 100% + |

The screenshot displays a PowerPoint presentation slide. On the left, a full view of a green printed circuit board (PCB) is shown, which is an RS485 adapter. A red rectangular box highlights the RS485 connector at the bottom of the board. On the right, a smaller image shows the same board installed inside a piece of HVAC equipment. A red rectangular box highlights the terminals labeled 'X', 'Y', and 'P' on the board, which are connected to the equipment's bus.

Type here to search

47°F Clear 8:12 PM 11/15/2021

PURCHASING THE RS485 ADAPTER.



38VMH: 3-Phase Heat Pump | Microsoft PowerPoint - Carrier B | Amazon.com: Gearmo Pro 5ft. USB to RS-485 Adapter

amazon.com/Gearmo-Pro-RS485-RS422-FTDI-Chip/dp/B005CPLOVW/ref=sr_1_14?crid=1KXPGC6G87ZUD&keywords=rs485+adapter&qid=1637025307&sprefix=rs+485+%... ☆

amazon prime Deliver to steven Buford 30519 All rs485 adapter Hello, steven Account & Lists Returns & Orders Cart Subtotal \$379.98

All Buy Again Groceries Amazon Basics Coupons Outdoor Recreation Pet Supplies Livestreams Shopper Toolkit Health & Household Hit movies starting at \$2.99

Computers Laptops Desktops Monitors Tablets Computer Accessories PC Components PC Gaming Deals

amazon live Kandi Burruss livestreams her must-have products Watch now amazon.com/live

Back to results



Gearmo Pro 5ft. USB to RS-485/422 Serial Adapter FTDI Chip - Windows 10 Supported

Visit the Gearmo Store
★★★★☆ 67 ratings | 17 answered questions

Price: \$28.88 ✓prime & FREE Returns

Thank you for being a Prime Member. Get \$125 off: Pay \$0.00 ~~\$28.88~~ upon approval for the Amazon Business Prime Card. Terms apply.

May be available at a lower price from other sellers, potentially without free Prime shipping.

Connector Type	USB Type A
Brand	Gearmo
Warranty Type	Limited

Buy new: \$28.88
✓prime & FREE Returns
FREE delivery: Wednesday, Nov 17
Order within 3 hrs and 44 mins
Details

Deliver to steven - Buford 30519

In Stock.

Qty: 1

Add to Cart Buy Now

Secure transaction

Ships from Amazon
Sold by Usbgear

Type here to search | 47°F Clear | 8:16 PM 11/15/2021

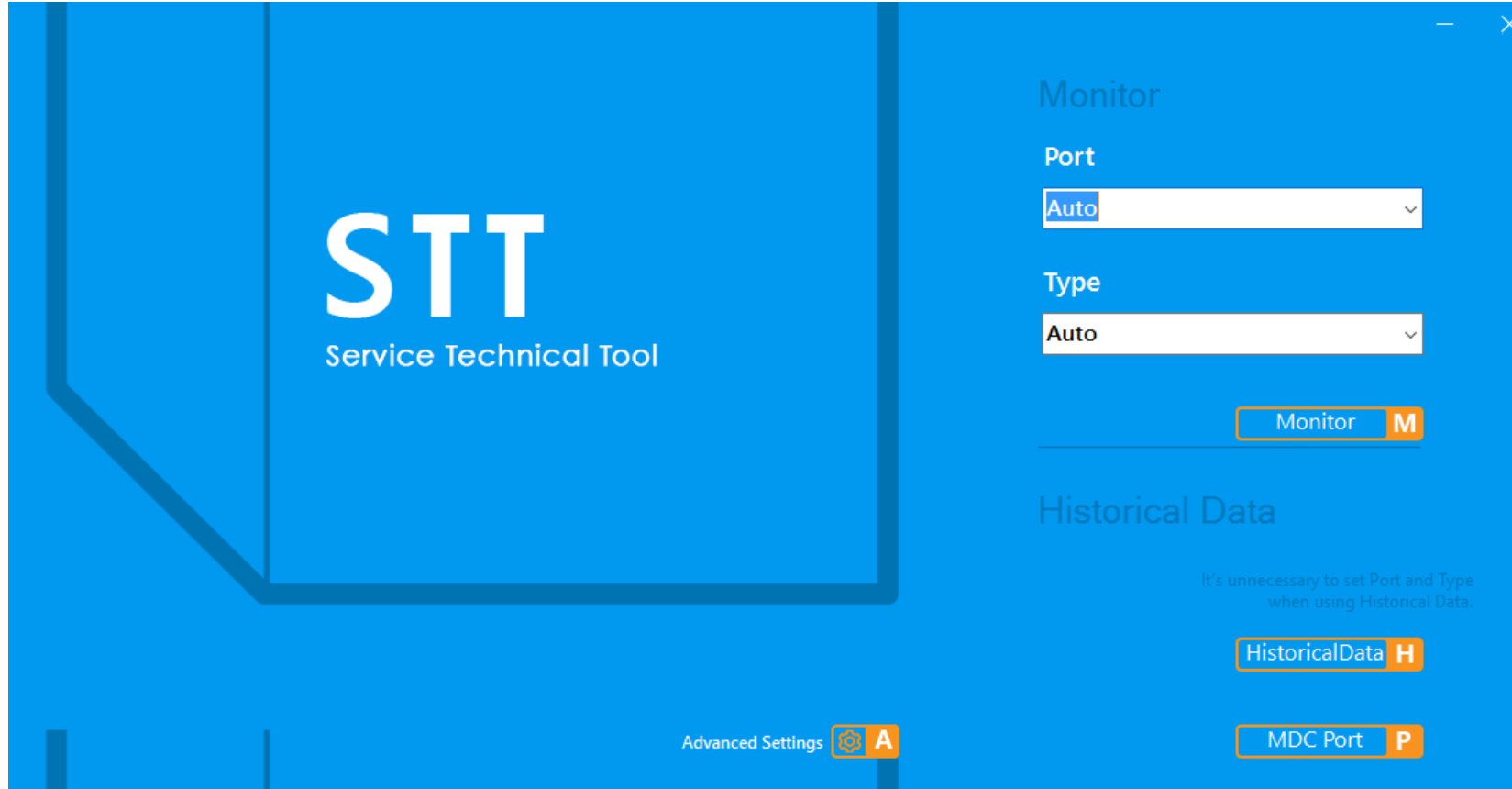

The screenshot shows the STT (Service Technical Tool) interface. On the left, the text "STT Service Technical Tool" is displayed. On the right, there are several settings and buttons:

- Monitor** section:
 - Port: Auto
 - Type: Auto
 - Monitor **M** button
- Historical Data** section:
 - Text: "It's unnecessary to set Port and Type when using Historical Data."
 - HistoricalData **H** button
 - MDC Port **P** button
- Advanced Settings** **A** button (with a gear icon)

STT Service Technical Tool — ×

HISTORY DATA ⚙️ A

1262 / 2428 Frame NO
09/23/2021 14:42:30 Date Time
P Data Selction ▾ Condition ▾ Search range S

Pre Frame Next Auto Play

System Status

System

Total Ton	5	IDU Qty.	2
ODU Qty.	1	Qty.IDU ON	1

ODU

Header

Type	Mini VRF
Mod	COOL
Ton	5
INV1	0

Error	000
-------	-----

IDU ☐ Select All

COOL	A	30	OFF	OF	30
Unlock	0	Unlock	1		
Room Temp	62	Room Temp	72		
Setpoint	62	Setpoint	--		
Error Code	00	Error Code	00		

COOL	A	30	OFF	OF	30
Unlock	0	Unlock	1		
Room Temp	62	Room Temp	72		
Setpoint	62	Setpoint	--		
Error Code	00	Error Code	00		

Lock Unlock

Room Temp -- °F

Setpoint

75 °F

Temp. + Temp. -

OFF ⏻

Cool ❄️

Heat ☀️

Dry 💧

Fan 🌀

High 🌀

Mid 🌀

Low 🌀

Auto 🌀

85

STT Service Technical Tool

HISTORY DATA ⚙️ A

Frame NO 1262 / 2428
Date Time 09/23/2021 14:42:30

Pre Frame Next Auto Play

Data Selction Condition Search range 🔍 S

Refrig System Diagram

ODU

IDU

01 ⌵ I Auto Switch G

00	00
62	62
A	A
00	00
00	00
00	00

STT Service Technical Tool

HISTORY DATA

Frame NO 1262 / 2428
Date Time 09/23/2021 14:42:30

Pre Frame Next Auto Play

Data Selection Condition Search range

Refrig System Detail

ODU

COOL Total Ton 5
ODU Qty. 1

Header O

INV 1 Error Code 000

IDU

Total KBTU/h 60
IDU Qty. 2
Qty.IDU ON 1

0 I **Auto Switch** G

KBTU/h 30 Mode COOL
Req. Cap. 3
Type VERT Error Code 00

The diagram illustrates a refrigeration system with the following components and status:

- ODU (Outdoor Unit):** COOL mode, 5 Total Ton, 1 ODU Qty.
- IDU (Indoor Unit):** 30 KBTU/h, COOL mode, 3 Req. Cap., VERT Type, Error Code 00.
- HP (High Pressure):** 203
- ST1 (Suction Temperature):** OFF
- SV4 (Suction Valve):** ON
- SV5 (Suction Valve):** OFF
- SV6 (Suction Valve):** OFF
- EXVA (Evaporator Valve):** 304
- EXV (Expansion Valve):** 300
- IHX (Indoor Heat Exchanger):** 62
- Temperature Sensors:** T1 (62), T2A (63), T2B (69), T3 (70), T4 (72), T5 (72)
- FAN1/FAN2 (7):** Status unknown
- INV1 (Inverter):** 0, 1, OFF

STT Service Technical Tool

HISTORY DATA

Frame NO 466 / 1147
Date Time 02/12/2018 15:31:20

Pre Frame Next Auto Play

System/T4 100

Data Graph

Chart A

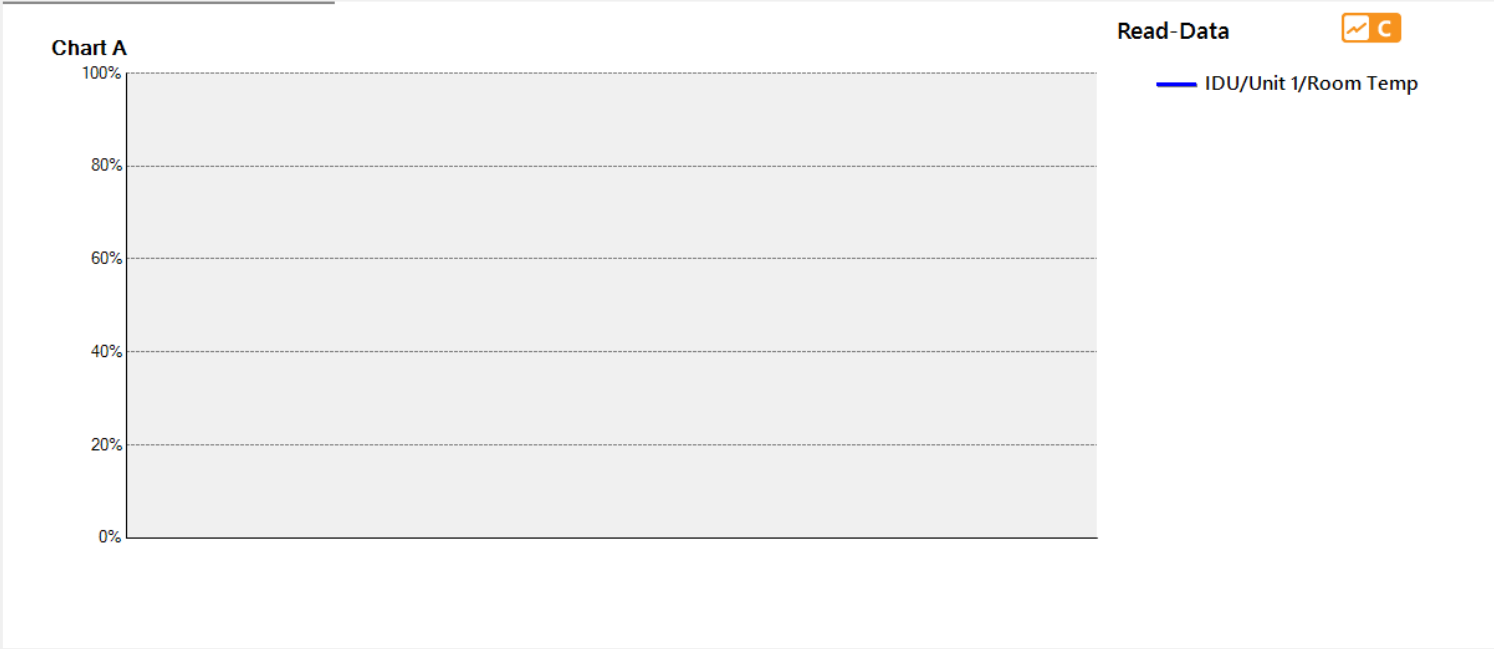

Read-Data

— IDU/Unit 1/Room Temp

STT Service Technical Tool

HISTORY DATA

Frame NO 466 / 1147
Date Time 02/12/2018 15:31:20

Pre Frame Next Auto Play System/T4 100

System Data

ODU

ODU Data	
	Header
Type	HR
Ton	6
ODU-Demand	0
OnOff	0
ErrorCode	000
Mode	M_HEAT
Night Silent	0
Mode change signal	0
PI	0
T4	58
HP	188.5
LP	172.55
INV Qty.	0
INV1 RPS	0
FF	0

IDU Data				
	1	2	3	4
Type	CCASS	LDUCT	UCF	VERT
KBTU/h	9	9	12	18
ErrorCode	00	00	00	00
Mode	OFF	OFF	OFF	OFF
Demand	0	0	0	0
Setpoint	--	--	--	--

System Data	
Total Ton	6
Type	HR
ODU Qty.	1
IDU Qty.	6
Qty.IDU ON	1
Mode	M_HEAT
Defrosting	0

STT Service Technical Tool

HISTORY DATA

Frame NO 466 / 1147
Date Time 02/12/2018 15:31:20

System/T4 100

Code List

ERROR CODE	Type	Definition
0E0	ODU	Commun
0E1	ODU	Open ph
0E2	ODU	(T)Comm
0E4	ODU	Temperat
0E5	ODU	Voltage p
0E6	ODU	DC fan er
0E7	I/F	Discharg
0E8	ODU	Incorrect
0E9	ODU	EEPROM
0EA	ODU	DC fans s
0EB	ODU	DC fan er
0H0	ODU	Commun
0H1	ODU	Commun
0H2	ODU	Inconsist
0H3	ODU	Inconsist
0H4	ODU	3 times o

Detailed Information

Supposed causes:

- Incorrect address setting of ODU
- Communication lines between ODUs not connected well or incorrect
- Wiring between main board and communication adapter not connected well
- Damaged main board or communication terminal block of ODU

```

graph TD
    Start([Turn off the power supply of ODU]) --> D1{Check whether the address setting of ODU is incorrect}
    D1 -- YES --> A1[Reset address for ODU ENC1 toggle switch:  
0 means: master unit  
1 means: slave unit 1  
2 means: slave unit 2]
    D1 -- NO --> D2{Check whether communication lines between ODUs are in short, open or connected incorrectly}
    D2 -- YES --> A2[Reconnect the communication line according to the wiring nameplate]
    D2 -- NO --> Next[ ]
  
```

KNOW YOUR SOURCES.



Havcpartners.com

Training.mingledorffs.com

slocicero@mingledorffs.com

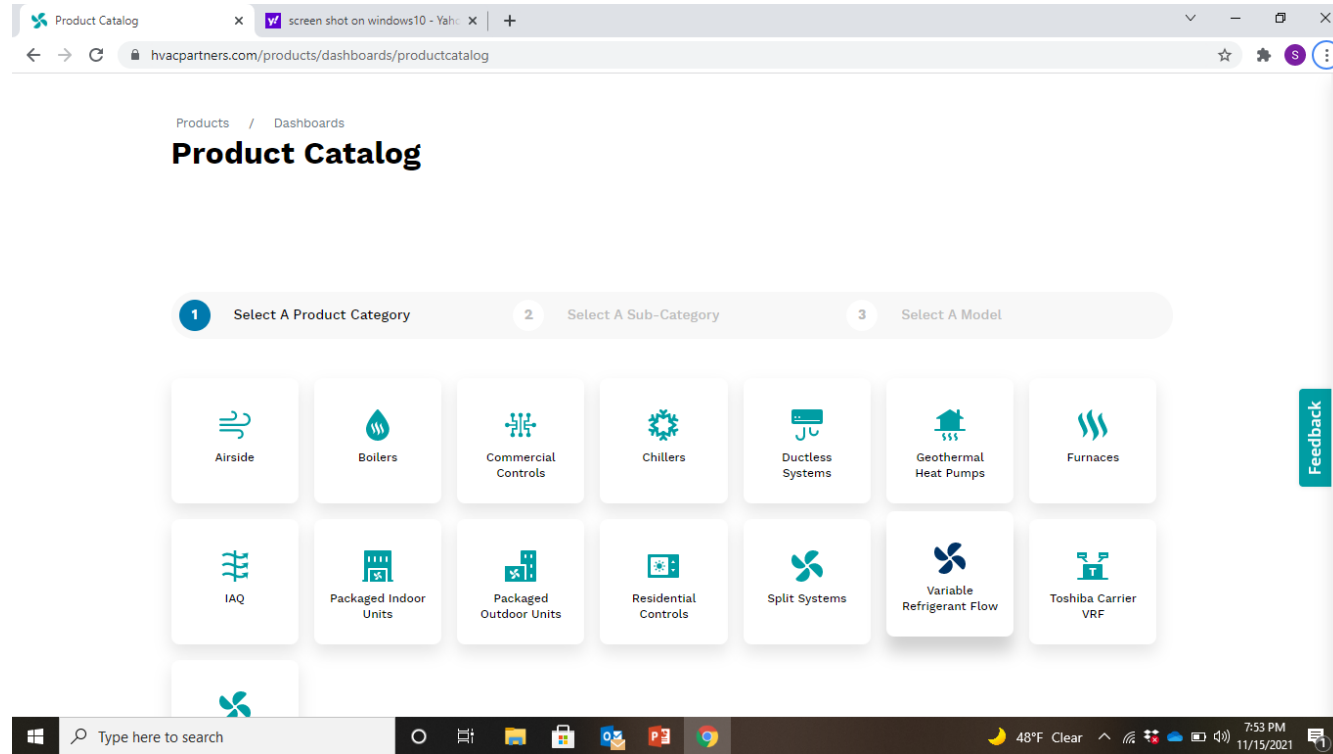

The screenshot shows a web browser window with the URL `hvacpartners.com/products/dashboards/productcatalog`. The page title is "Product Catalog" and the breadcrumb is "Products / Dashboards". A progress bar at the top indicates three steps: "1 Select A Product Category", "2 Select A Sub-Category", and "3 Select A Model". The main content area features a grid of 14 HVAC product categories, each with an icon and a label: Airside, Boilers, Commercial Controls, Chillers, Ductless Systems, Geothermal Heat Pumps, Furnaces, IAQ, Packaged Indoor Units, Packaged Outdoor Units, Residential Controls, Split Systems, Variable Refrigerant Flow, and Toshiba Carrier VRF. A "Feedback" button is located on the right side of the page. The Windows taskbar at the bottom shows the search bar, task icons, system tray, and the date/time "7:53 PM 11/15/2021".

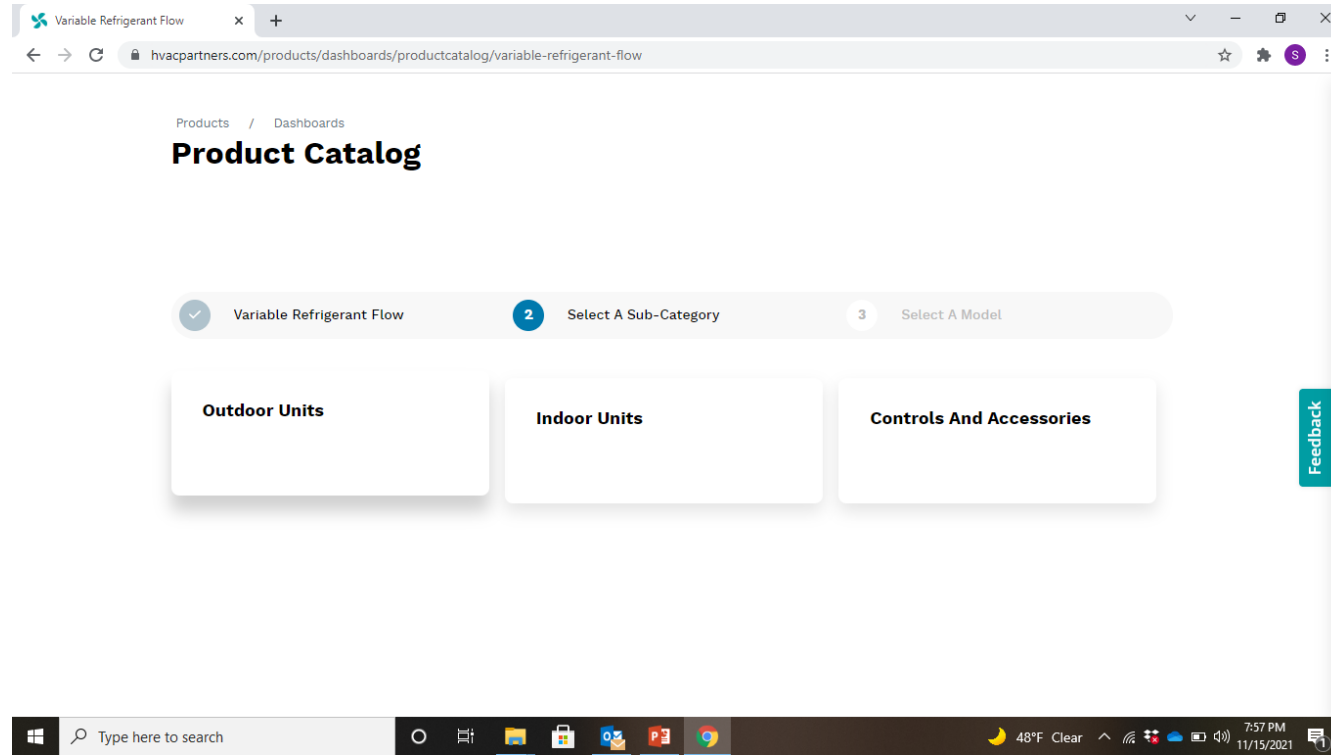

The screenshot shows a web browser window with the URL `hvacpartners.com/products/dashboards/productcatalog/variable-refrigerant-flow`. The page title is "Product Catalog" under the breadcrumb "Products / Dashboards". A navigation bar contains three steps: "Variable Refrigerant Flow" (selected), "Select A Sub-Category", and "Select A Model". Below this are three main category buttons: "Outdoor Units", "Indoor Units", and "Controls And Accessories". A vertical "Feedback" button is on the right. The Windows taskbar at the bottom shows the search bar, taskbar icons, and system tray with a temperature of 48°F and date 11/15/2021.

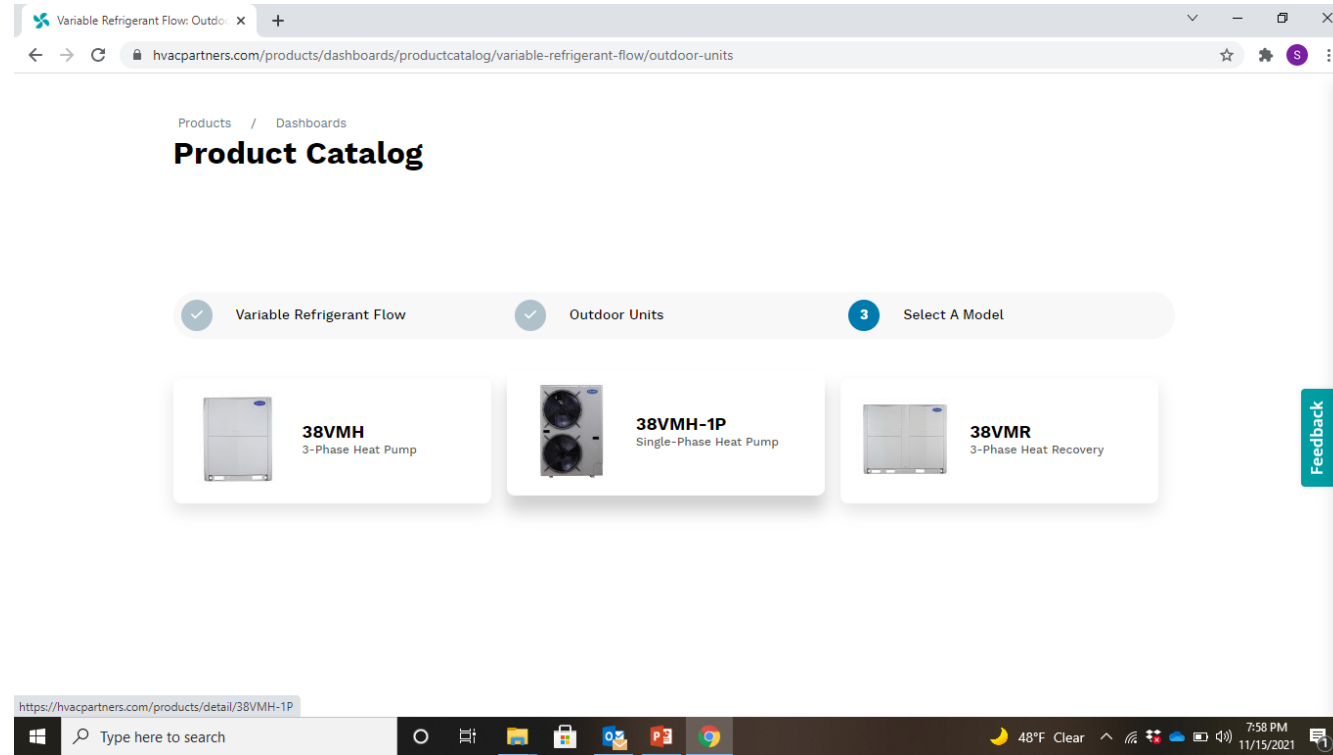



Variable Refrigerant Flow: Outdoor x +

hvacpartners.com/products/dashboards/productcatalog/variable-refrigerant-flow/outdoor-units

Products / Dashboards

Product Catalog

Variable Refrigerant Flow Outdoor Units **3** Select A Model

-  **38VMH**
3-Phase Heat Pump
-  **38VMH-1P**
Single-Phase Heat Pump
-  **38VMR**
3-Phase Heat Recovery

Feedback

https://hvacpartners.com/products/detail/38VMH-1P

Type here to search

48°F Clear 7:58 PM 11/15/2021

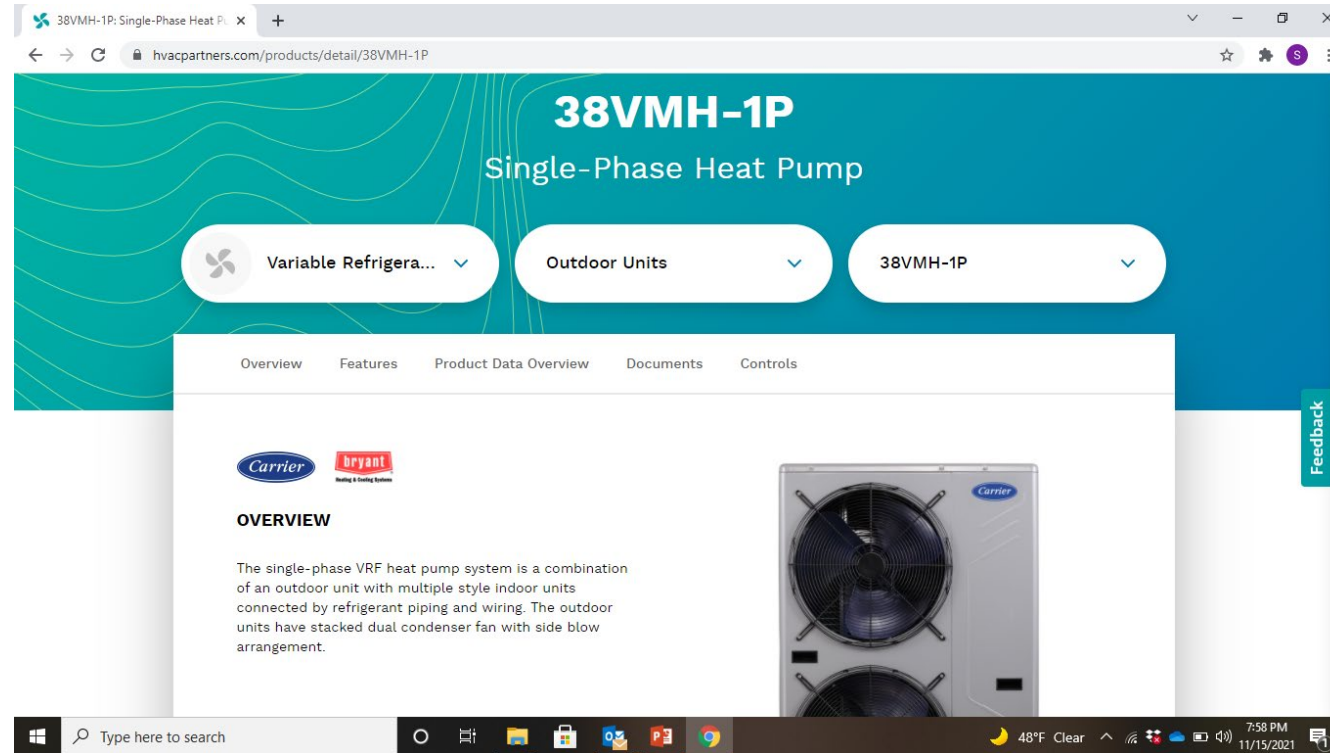

The screenshot shows a web browser window displaying the product page for the 38VMH-1P Single-Phase Heat Pump. The browser's address bar shows the URL `hvacpartners.com/products/detail/38VMH-1P`. The page features a teal header with the product name and three filter buttons: "Variable Refrigera...", "Outdoor Units", and "38VMH-1P". Below the header is a navigation menu with links for "Overview", "Features", "Product Data Overview", "Documents", and "Controls". The main content area includes the Carrier and Bryant logos, an "OVERVIEW" section with descriptive text, and an image of the outdoor unit. A "Feedback" button is visible on the right side of the page. The Windows taskbar at the bottom shows the search bar, application icons, and system tray information including the date and time (7:58 PM, 11/15/2021).

38VMH-1P
Single-Phase Heat Pump

Variable Refrigera... Outdoor Units 38VMH-1P

Overview Features Product Data Overview Documents Controls

Carrier bryant
Building & Cooling Solutions

OVERVIEW

The single-phase VRF heat pump system is a combination of an outdoor unit with multiple style indoor units connected by refrigerant piping and wiring. The outdoor units have stacked dual condenser fan with side blow arrangement.

Feedback

Type here to search 48°F Clear 7:58 PM 11/15/2021

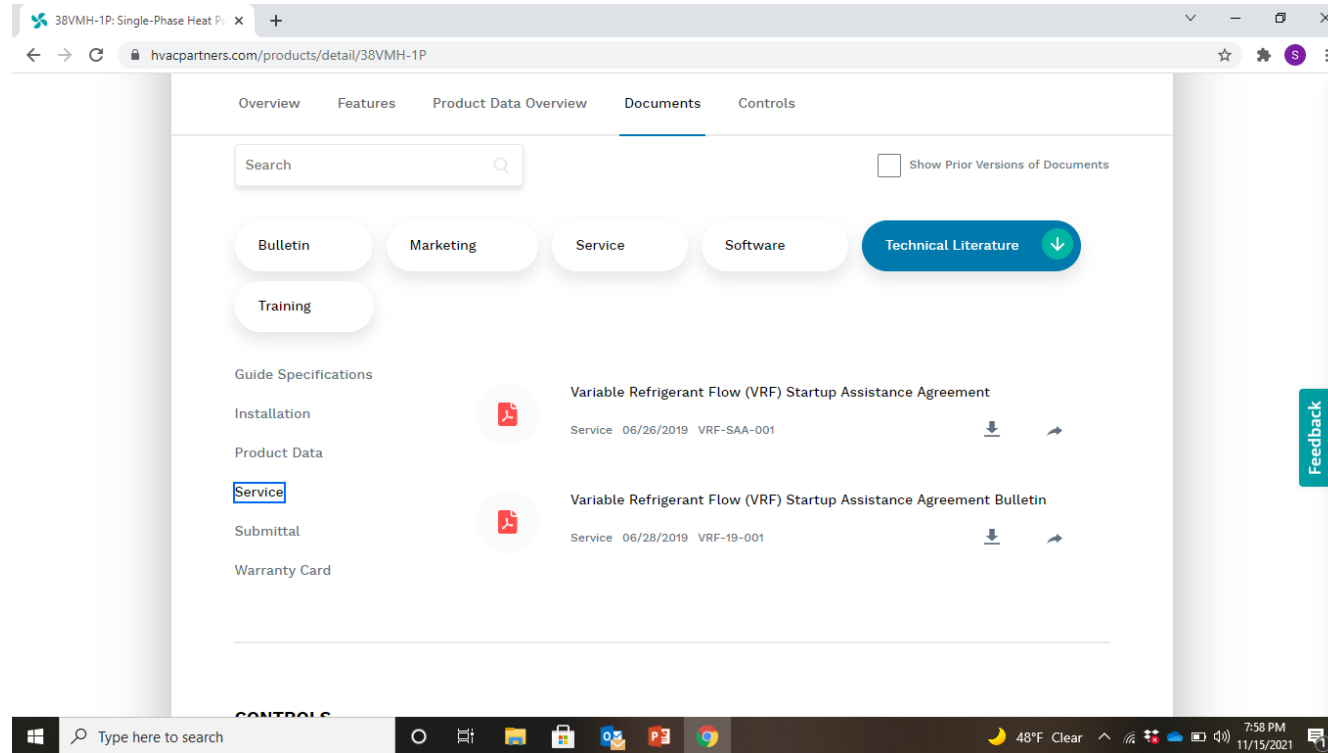

38VMH-1P: Single-Phase Heat P... x

hvacpartners.com/products/detail/38VMH-1P

Overview Features Product Data Overview Documents Controls

Search Show Prior Versions of Documents

Bulletin Marketing Service Software Technical Literature Training

Guide Specifications

Installation

Product Data

Service

Submittal

Warranty Card

Variable Refrigerant Flow (VRF) Startup Assistance Agreement
Service 06/26/2019 VRF-SAA-001

Variable Refrigerant Flow (VRF) Startup Assistance Agreement Bulletin
Service 06/28/2019 VRF-19-001













Feedback

Type here to search

48°F Clear 7:58 PM 11/15/2021

Variable Refrigerant Flow: Indoor

hvacpartners.com/products/dashboards/productcatalog/variable-refrigerant-flow/indoor-units

 40VMA Outside Air Duct	 40VMC Compact 4-Way Cassette	 40VMD Multiport Distribution Controller
 40VMF 4-Way Cassette	 40VMH High Static Duct	 40VMI One-Way Cassette
 40VML Low Static Duct	 40VMM Medium Static Duct	 40VMR Floor Console - Recessed
 40VMU Underceiling / Floor Console - Exposed	 40VMV Vertical Air Handler Unit	 40VMW High Wall
 40VMZ Reheat Unit		

Feedback

Type here to search

48°F Clear 7:59 PM 11/15/2021



40VM900001
Wireless Remote Controller



40VM900002
Carrier Non-Programmable Wired Remote Controller



40VM900003
Carrier Programmable Wired Remote Controller



40VM900005
Carrier Touch Screen Wired Controller



40VM900006
Carrier Touch Screen Central Controller



40VM900007
ERV Interface (DI/DO)



40VM900008
24V Interface



40VM900010
VRF/DLS Interface



40VM900012
Non-Programmable Wired Remote Controller



40VM900013
Programmable Wired Remote Controller



40VM900051
Energy Monitoring Module



40VM900052
Carrier BACnet® Interface

Feedback

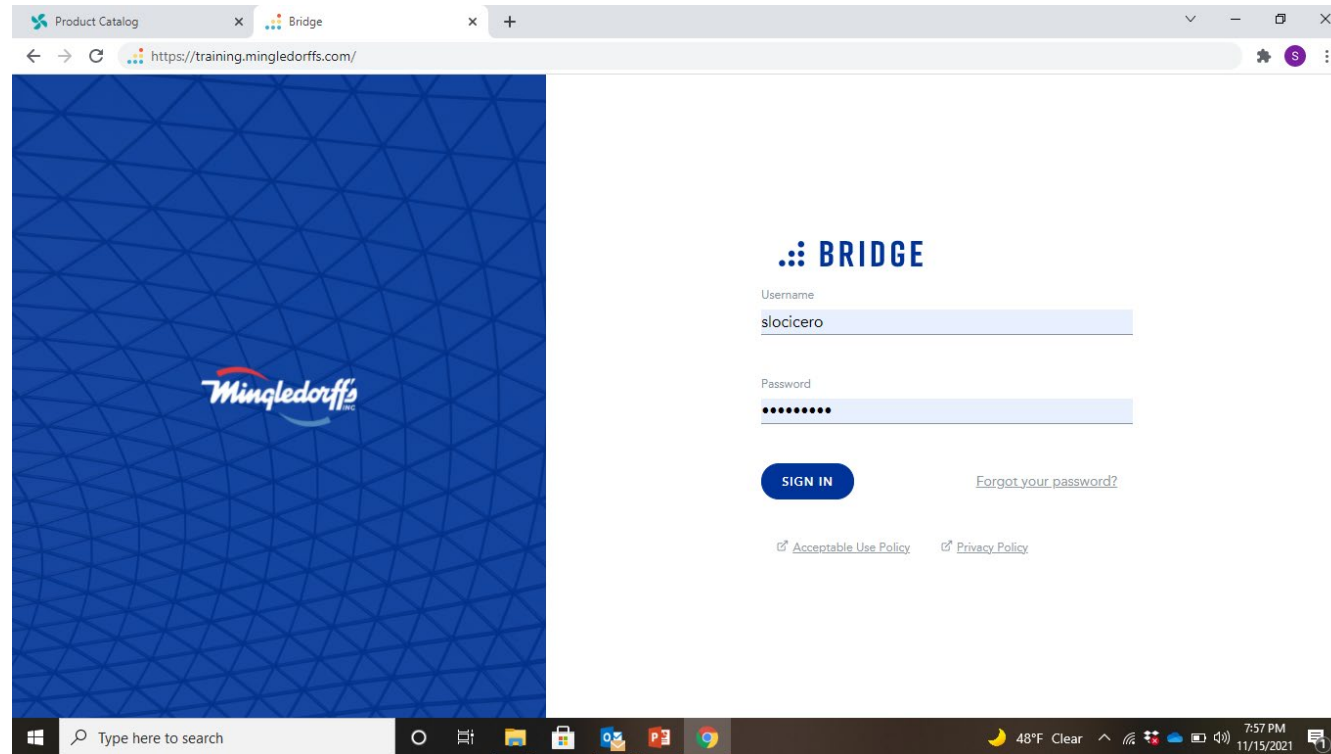

Product Catalog x Bridge x +

https://training.mingledorffs.com/

BRIDGE

Username
slocicero

Password
.....

SIGN IN [Forgot your password?](#)

[Accetable Use Policy](#) [Privacy Policy](#)

Type here to search

48°F Clear 7:57 PM 11/15/2021

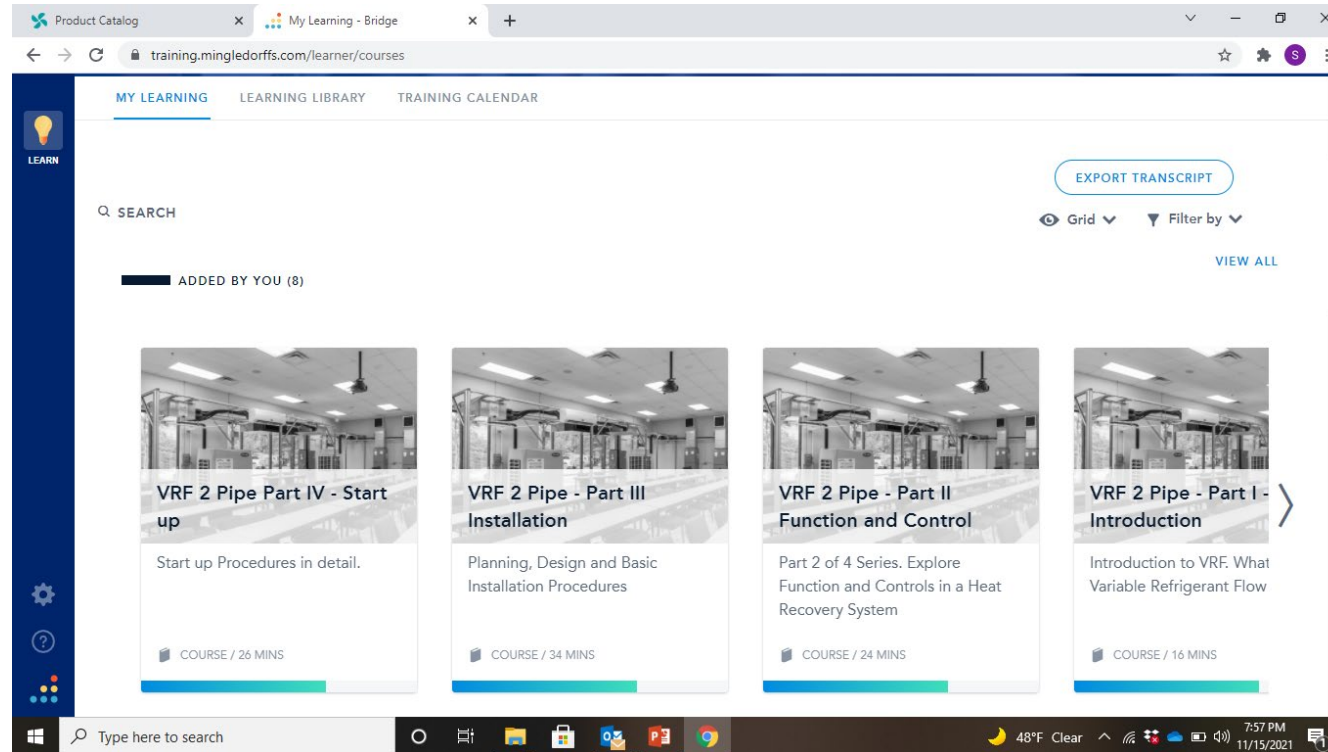

The screenshot shows a web browser window with two tabs: 'Product Catalog' and 'My Learning - Bridge'. The address bar shows the URL 'training.mingledorffs.com/learner/courses'. The page has a dark blue sidebar on the left with a 'LEARN' button and a search icon. The main content area has a navigation bar with 'MY LEARNING', 'LEARNING LIBRARY', and 'TRAINING CALENDAR'. Below this is a search bar and an 'EXPORT TRANSCRIPT' button. A section titled 'ADDED BY YOU (8)' contains four course cards, each with a thumbnail image of a training facility. The cards are: 'VRF 2 Pipe Part IV - Start up' (26 mins), 'VRF 2 Pipe - Part III Installation' (34 mins), 'VRF 2 Pipe - Part II Function and Control' (24 mins), and 'VRF 2 Pipe - Part I - Introduction' (16 mins). The Windows taskbar at the bottom shows the search bar, task icons, and system tray with a temperature of 48°F and the date 11/15/2021.

Product Catalog | My Learning - Bridge

training.mingledorffs.com/learner/courses

MY LEARNING | LEARNING LIBRARY | TRAINING CALENDAR

LEARN

EXPORT TRANSCRIPT

SEARCH

Grid | Filter by

VIEW ALL

ADDED BY YOU (8)

- VRF 2 Pipe Part IV - Start up**
Start up Procedures in detail.
COURSE / 26 MINS
- VRF 2 Pipe - Part III Installation**
Planning, Design and Basic Installation Procedures
COURSE / 34 MINS
- VRF 2 Pipe - Part II Function and Control**
Part 2 of 4 Series. Explore Function and Controls in a Heat Recovery System
COURSE / 24 MINS
- VRF 2 Pipe - Part I - Introduction**
Introduction to VRF. What Variable Refrigerant Flow
COURSE / 16 MINS

Type here to search | 48°F Clear | 7:57 PM 11/15/2021

- For further VRF assistance email me at slocicero@mingledorffs.com
- This is best way to get a response about the product or ask for assistance in installation or service.
- Contact your TM to get a log in for HVAC partners or the Bridge.



THANK YOU